

INFINITYFLO

PUMPS (PTY) LTD

SELF PRIMER



MATERIALS OF CONSTRUCTION

	Standard CI	Type A CI/A216	Type B CI/CD4	Type C CI/304SS	Type D CI/ADI	Type E CD4MCU	Type F 316SS	Type F1 304SS	Type G ADI	Type H Hastelloy C276	
Casing	A48 CL30					CD4MCU	316SS	304SS	ADI	C276	
Impeller	A60 4018	A216	CD4MCU	304SS	ADI	CD4MCU	316SS	304SS	ADI	C276	
Wear Plate	SAE 1020	A216	CD4MCU	304SS	ADI	CD4MCU	316SS	304SS	ADI	C276	
Cover Plate	A48 CL30	A216	CD4MCU	304SS	ADI	CD4MCU	316SS	304SS	ADI	C276	
Bearing Housing	A48 CL30					CD4MCU	316SS	304SS	ADI	C276	
Seal Plate	A48 CL30	A216	CD4MCU	304SS	ADI	CD4MCU	316SS	304SS	ADI	C276	
Flap Valve	Neoprene					Viton					
Shaft Sleeve	316SS										
Flange	A48 CL30					CD4MCU	316SS	304SS	ADI	C276	
O'Rings	Buna			Viton							
Shaft	ANSI 4140			17-4 ss			17-4 ss		17-4 ss		17-4 ss
Mechanical Seal	Casing in 316SS, O'Rings in Viton, Facesin Titanium and Tungsten Carbide										

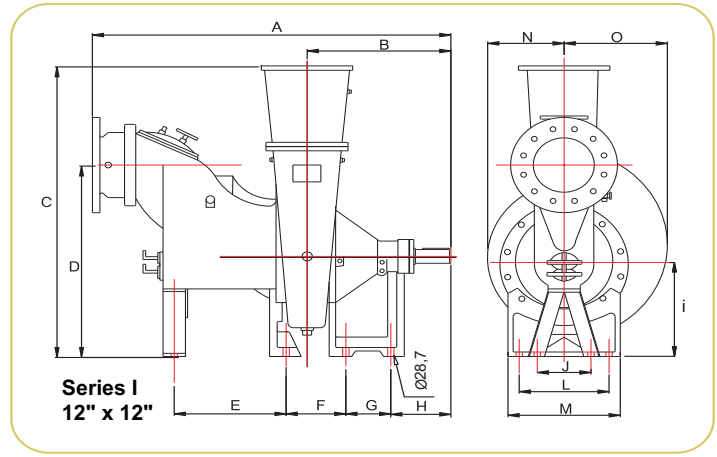
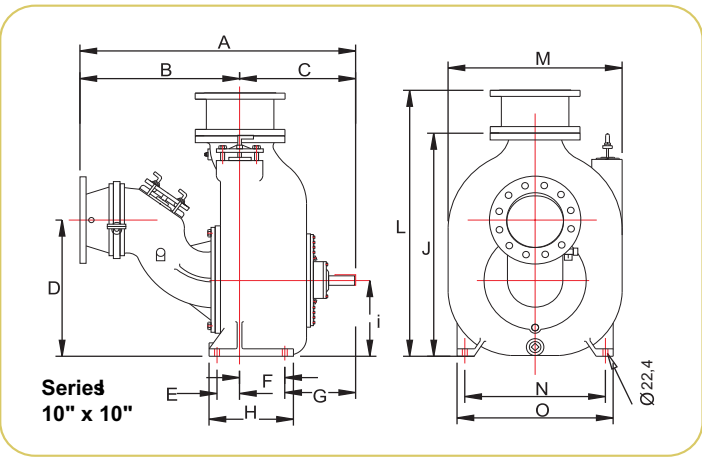
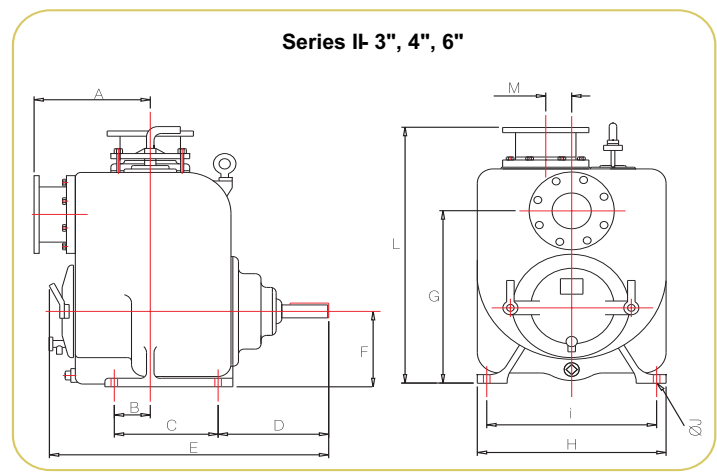
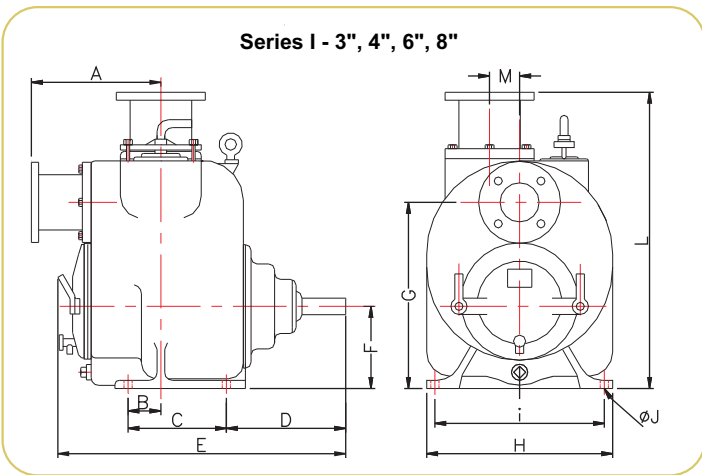

Series I

	2"	3"	4"	6"	8"	10"	12"
A	235.0	293.7	317.5	406.4	412.8	1237.2	1621.5
B	54.0	76.2	77.8	77.8	101.6	712.0	650.0
C	163.2	228.6	280.0	279.4	304.8	525.3	1474.7
D	275.0	284.2	293.7	293.7	407.1	636.5	971.5
E	547.0	668.3	768.4	801.7	1023.1	101.6	508.0
F	151.5	190.5	222.2	257.2	330.2	204.3	270.0
G	318.0	431.8	495.4	568.3	723.9	320.8	203.2
H	308.3	431.8	501.7	577.9	704.9	381.0	272.5
i	281.0	393.7	457.2	527.0	635.0	355.6	508.0
J	14.0	17.5	17.5	17.5	22.4	1041.4	242.6
d	38.1	38.1	38.1	38.1	44.5	44.5	69.9
L	523.0	687.4	743.0	896.9	1068.3	1220.7	406.4
M	70.0	70.0	70.0	70.0		785.9	508.0
N						635	345.9
O						704.9	466.9
Q	101.6	101.6	127.0	127.0	169.9	122.2	167.4

Series II

	3"	4"	6"
A	292.1	317.5	406.4
B	76.2	96.8	77.7
C	228.6	279.4	279.4
D	282.9	297.5	330.7
E	666.8	751.6	844.6
F	190.5	222.2	257.0
G	431.8	508.0	568.4
H	431.8	508.0	584.2
i	394.0	457.2	527.2
J	17.5	17.5	17.5
d	38.1	38.1	44.5
L	686.8	749.3	897.1
M	69.8	69.8	69.8
N			
O			
Q	103.1	126.2	114.3

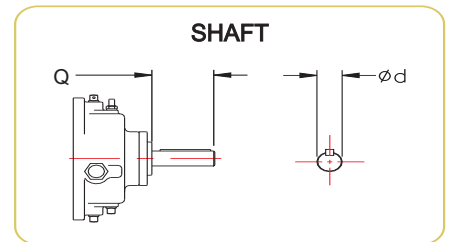

MAINTENANCE DISTANCE

Required in front of pump (to remove cover) and behind of pump (to remove rotating assembly)

Series I 2" - 6", 10", 12", Series II 3" - 6" : 460mm
Series I 8" : 610mm

FLANGES

According to Model number : Nominal bore, inch
Drilled to : BS4504 Table 16

SERIES I

Self Priming Curves

2" x 2"

Net Weight
92 kg
Shipping Weight
114 kg
Impeller Diameter
159 mm
Max Solids
Dia.
44.45 mm

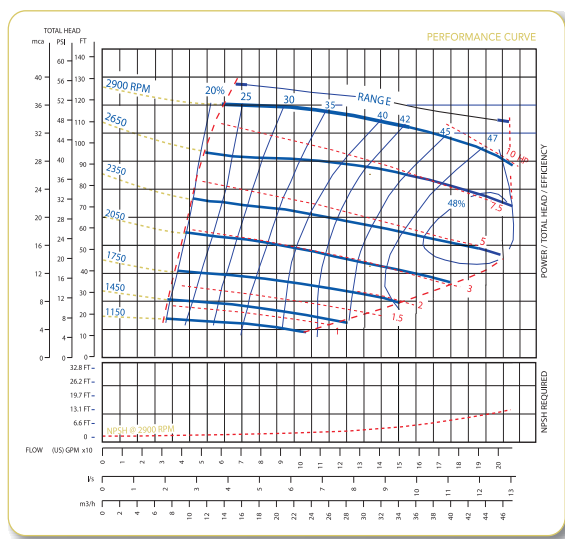

3" x 3"

Net Weight
183 kg
Shipping Weight
205 kg
Impeller Diameter
222 mm
Max Solids
Dia.
63.5 mm

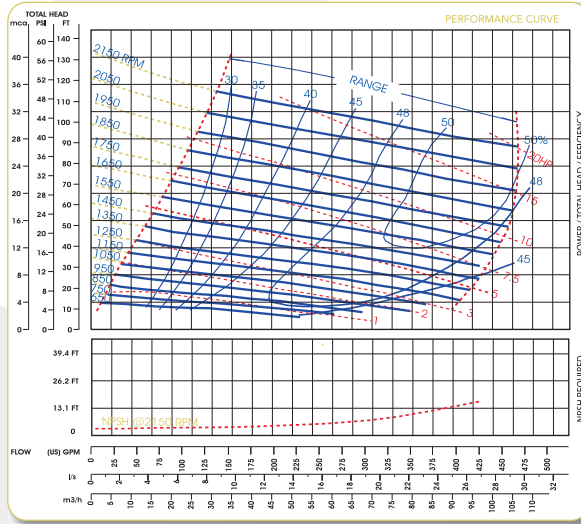

4" x 4"

Net Weight
260 kg
Shipping Weight
280 kg
Impeller Diameter
248 mm
Max Solids
Dia.
76.2 mm

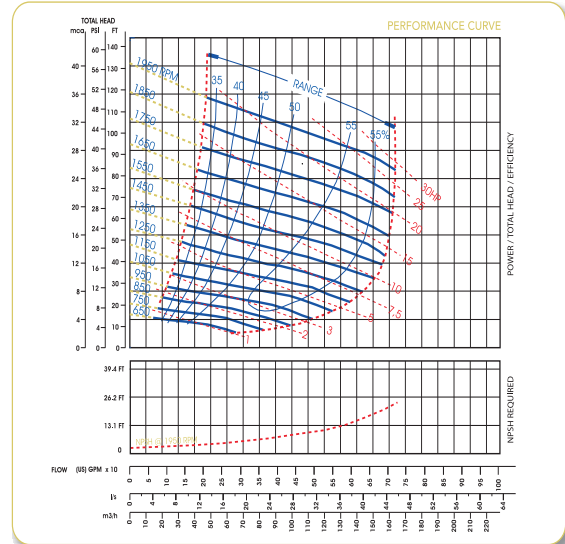

6" x 6"

Net Weight
364 kg
Shipping Weight
391 kg
Impeller Diameter
341 mm
Max Solids
Dia.
76.2 mm

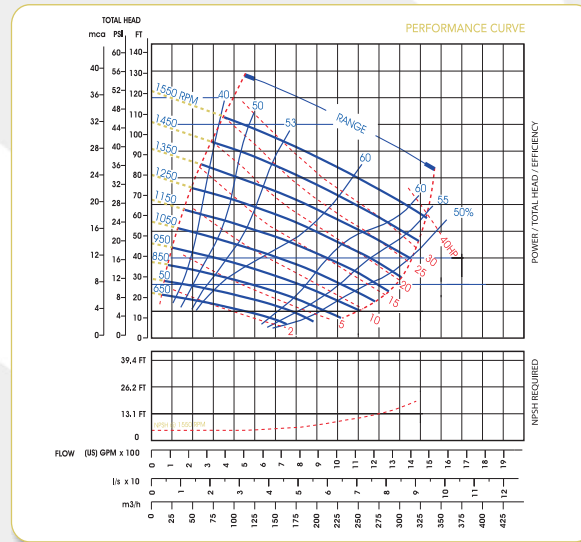

8" x 8"

Net Weight
581 kg
Shipping Weight
634 kg
Impeller Diameter
375 mm
Max Solids
Dia.
76.2 mm

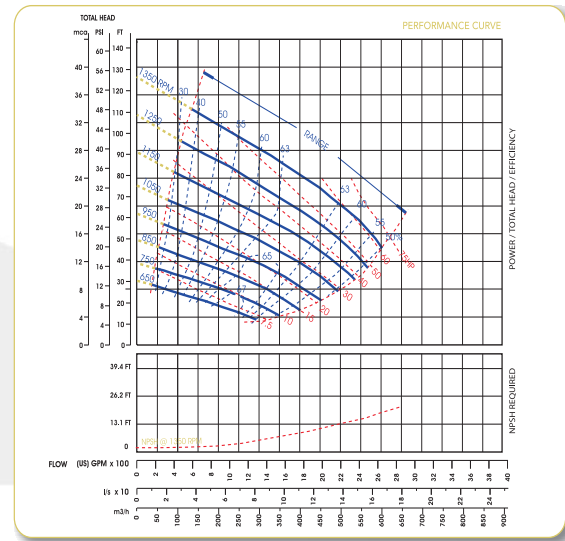

10" x 10"

Net Weight
635 kg
Shipping Weight
663 kg
Impeller Diameter
375 mm
Max Solids
Dia.
76.2 mm

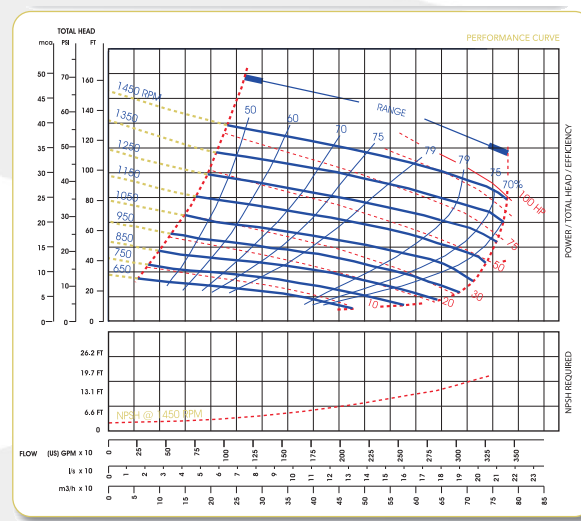

12" x 12"

Net Weight
998 kg
Shipping Weight
1066 kg
Impeller Diameter
457 mm
Max Solids
Dia.
76.2 mm

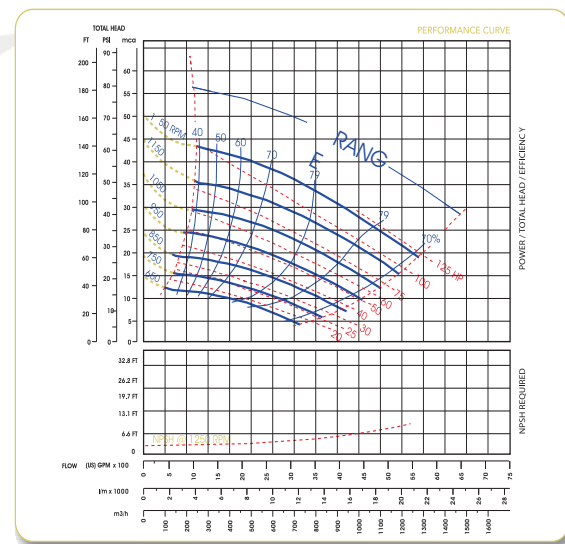

SERIES II

Self Priming Curves

3" x 3"

Net Weight
214 kg
 Shipping Weight
225 kg
 Impeller Diameter
279 mm
 Max Solids Dia.
20.6 mm

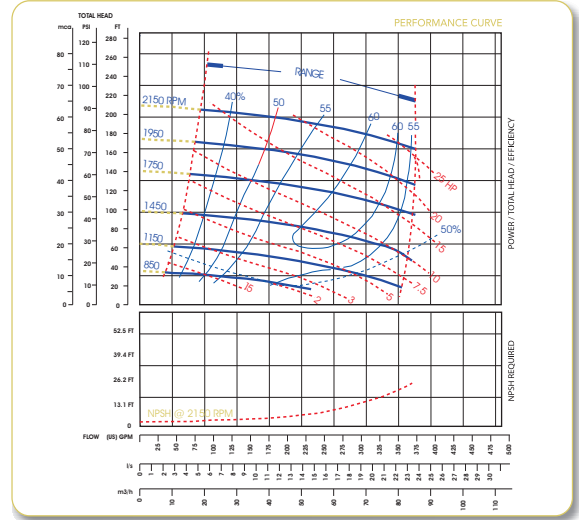

4" x 4"

Net Weight
272 kg
 Shipping Weight
297 kg
 Impeller Diameter
279 mm
 Max Solids Dia.
28.6 mm

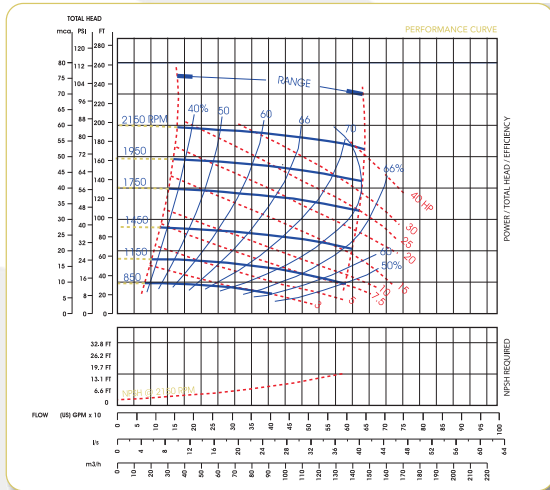

6" x 6"

Net Weight
413 kg
 Shipping Weight
437 kg
 Impeller Diameter
318 mm
 Max Solids Dia.
31.8 mm

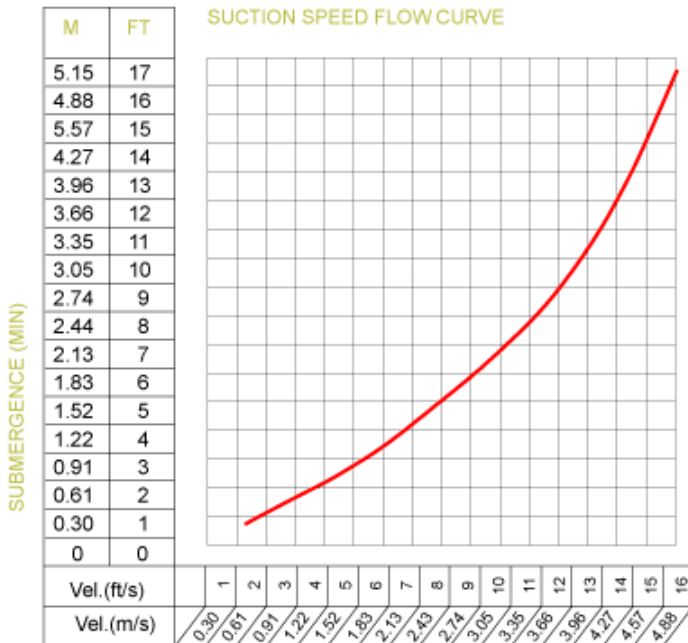
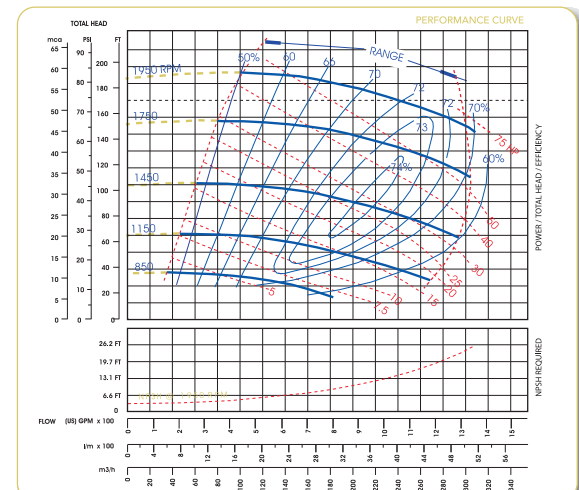

Note 1: The suggested suction should have the same nominal diameter as the pump, so that the solids will be totally swept up.

2: If the speed is higher than 3.5 m/s and if there is a need for higher "NPSH", please contact the factory.