

# Product Specification Guide

Technical information, installation requirements and guidance on industry legislation

# Global Interests

Offices in the UK,  
Hong Kong,  
India,  
Middle East and  
South Africa.

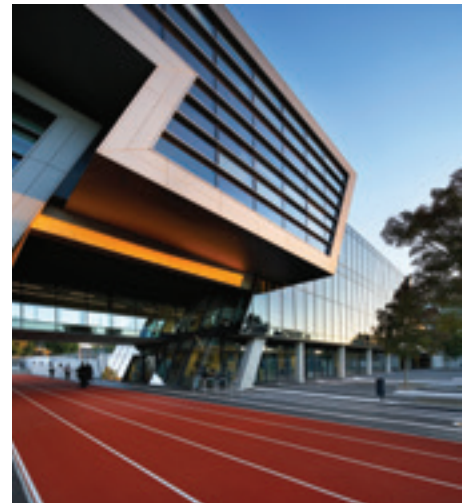

# Who We Are & What We Offer

SE Controls is a leading specialist in the design and delivery of smoke ventilation and environmental ventilation systems using façade automation as an integral part of the building envelope.

Since 1981 SE Controls has been developing innovative control systems that harness sustainable natural elements to create a safer and healthier indoor environment. This family owned business has grown from a humble start into an international business delivering products and projects across several continents.

Our customers benefit from qualified advice and technical support that is at the leading edge of international regulations and product development. Our products are designed and tested to international standards keeping our customers at the forefront of technology.

# Knowledge and Accreditation

SE Controls works closely with all significant industry bodies and leading roof light and vent manufacturers in testing our products as a combined fully compliant system to the required standards, such as EN 12101-2.



Profile specific 'Standard details' available on request.

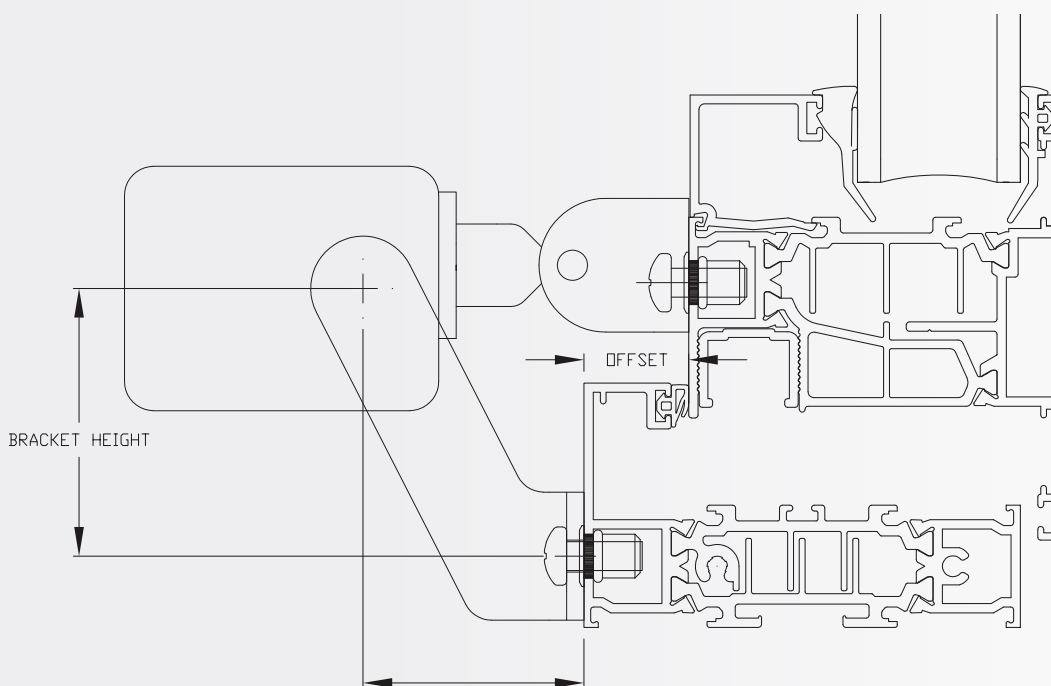

# Partner Support

## In house training



**All Partners are upskilled at our dedicated in house training facility to ensure that all their engineers have the correct knowledge base to understand and specify SE Controls' products.**

- Controls
- Actuators
- Standards & Legislation
- Product selection
- Installation
- Commissioning

## On site training



**All Partners are fully trained on site to ensure professional and accurate installation and commissioning of SE Controls' products.**

- On site guidance
- Supported by fully qualified SE Controls' engineers
- Validation of initial installation

## On site appraisals



**All Partner's installations will be subject to on going on site appraisals to ensure continued and consistent quality of installation.**

- Carried out by experienced SE Controls' engineers
- Additional training and support offered if required
- Feedback from appraisal available on request

### Plug and play solutions



**Remote access functionality available to SE Controls Partners using Sceptre Programmer to enable immediate analysis and troubleshooting of all on site queries.**

- Full remote commissioning of site available via WiFi
- Enables direct and immediate support via SE Controls Technical Support Team
- Ideal for long distance installation support (including overseas)

### Help is at hand



**With a wealth of industry knowledge gained over many years of both manufacturing and contract installation, SE Controls has the ability to support its Partners in all aspects of design and installation.**

- Technical Support Team
- Technical Support Engineers
- SE Controls Knowledge Hub
  - Online customer support system
  - Information library
  - FAQs
  - Out of hours support

### Partner accreditation



**All Partners are recognised through the SE Controls Recommended Partner certification scheme.**

- Certificate to confirm Recommended Partner status
- Partners are supported through continued training and development
- Partner status reviewed regularly

# Sceptre Programmer

The Sceptre Programmer is SE Controls' custom programming software tool which enables parameters to be set and adjusted to meet the requirements of individual installations.

- Remote access technical support for speedy resolution to on site complications
- Skilled and experienced engineers on hand for one to one support
- Downloadable controls history and data logging functionality (Excel)
- Enables onsite customisation of controller settings
- Service and diagnostic ability
- Ability to record and print event logs

## SCREENSHOT OF LIVE MONITOR PAGE

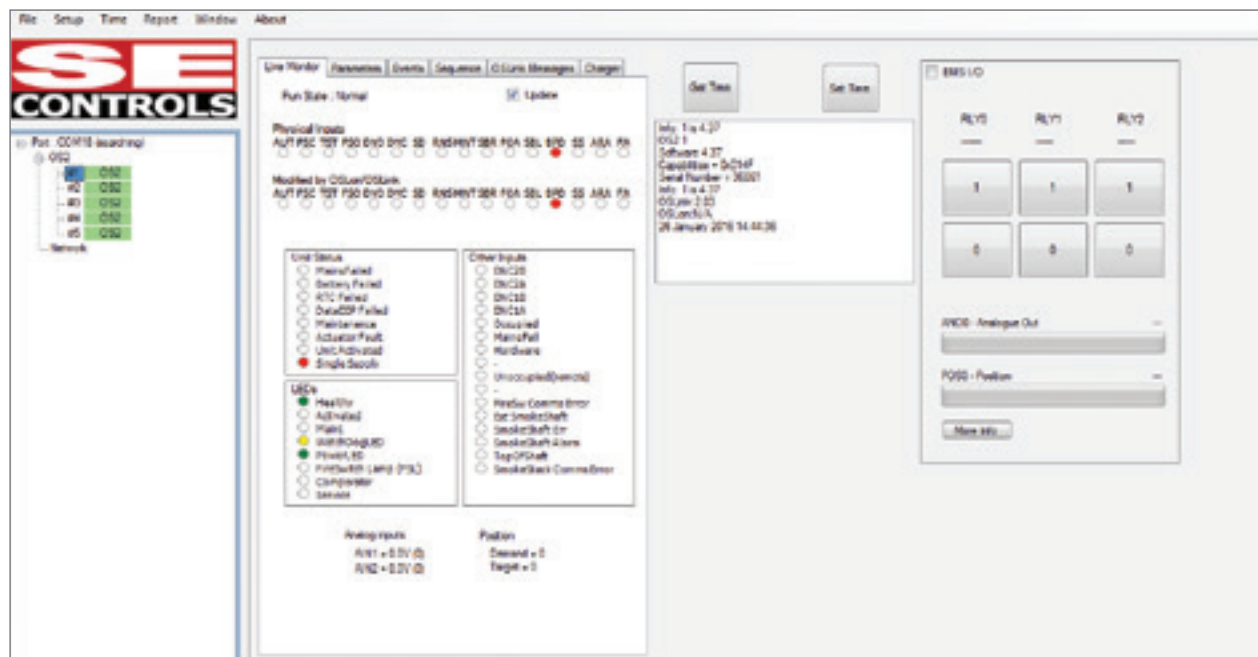

SCREENSHOT OF PARAMETERS PAGE

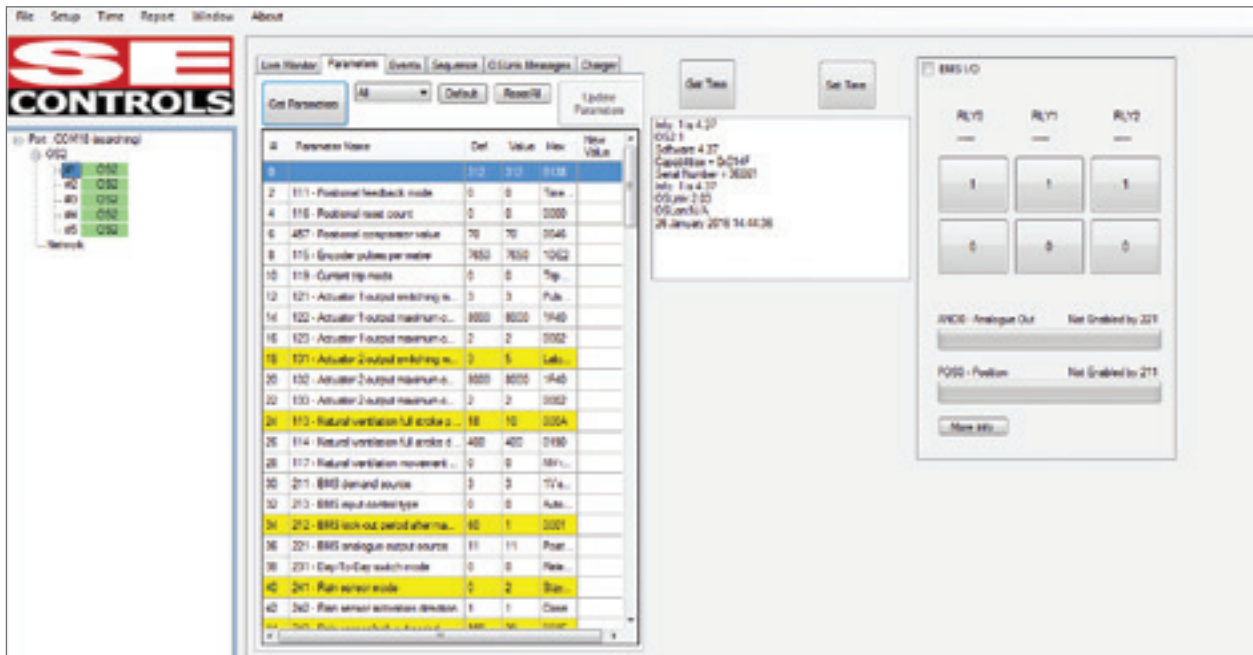

ID	Parameter Name	Def	Value	Min	New Value
0		0/0	0/0	0/0	0/0
2	111 - Position feedback mode	0	0	0	0
4	115 - Position reset count	0	0	0	0000
6	487 - Pressure compressor value	70	70	0	0040
8	115 - Graveler pulser per stroke	7650	7650	1000	
10	119 - Current trip mode	0	0	0	0
12	121 - Actuator faulted enabling s.	0	0	0	0
14	122 - Actuator faulted maximum c.	8000	8000	1940	
16	123 - Actuator faulted maximum s.	2	2	0	0002
18	121 - Actuator faulted enabling s.	0	5	0	0
20	130 - Actuator 2 output maximum s.	8000	8000	1940	
22	130 - Actuator 2 output maximum s.	2	2	0	0002
24	112 - Natural ventilation full stroke s.	18	18	10	0004
26	114 - Natural ventilation full stroke s.	400	400	0	0190
28	117 - Natural ventilation movement s.	0	0	0	0000
30	211 - BMS demand source	0	0	0	0100
32	213 - BMS aquastat type	0	0	0	0000
34	212 - BMS lock out period after ma.	60	1	0	0001
36	221 - BMS analogue output source	11	11	0	0000
38	231 - Day-to-Day switch mode	0	0	0	0000
40	241 - Rain sensor mode	0	2	0	0000
42	242 - Rain sensor activation direction	0	1	0	0000

SCREENSHOT OF EVENTS PAGE

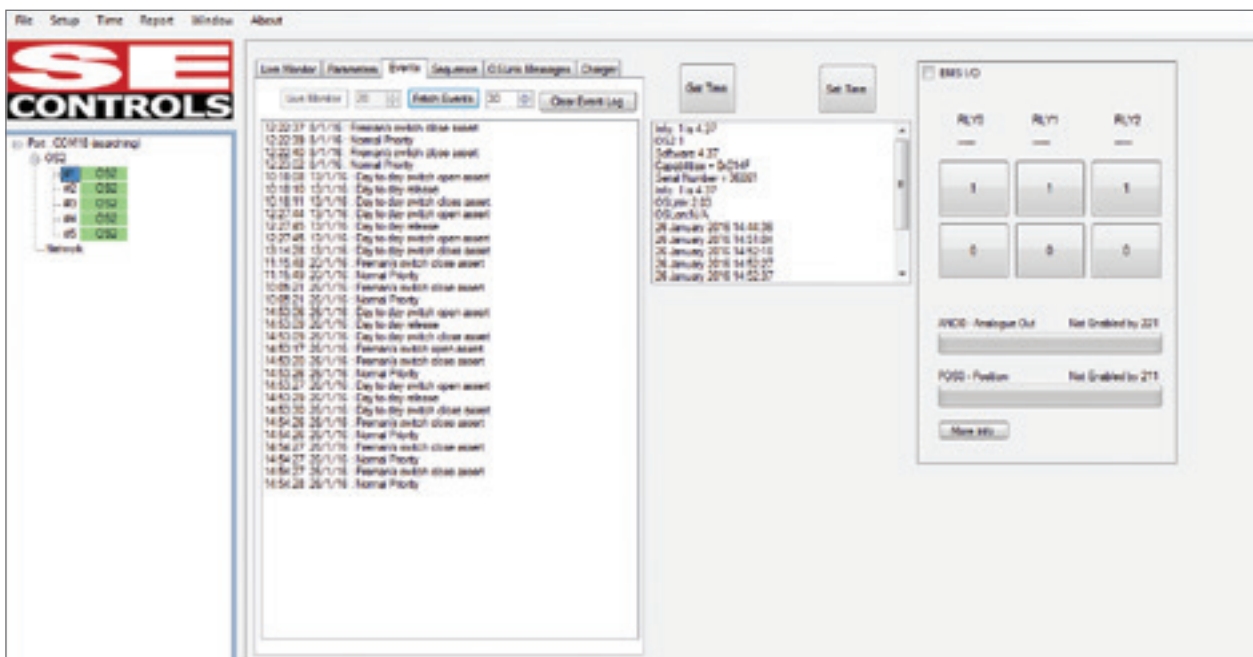

Time	Date	Description
12:20:37	3/1/18	Fearam's switch close event
12:20:38	3/1/18	Normal Priority
12:20:40	3/1/18	Fearam's switch close event
12:20:42	3/1/18	Normal Priority
12:18:08	12/1/18	Day to day switch open event
12:18:09	12/1/18	Day to day release
12:18:11	12/1/18	Day to day switch close event
12:21:04	12/1/18	Day to day switch open event
12:21:05	12/1/18	Day to day release
12:21:06	12/1/18	Day to day switch open event
12:14:28	12/1/18	Day to day switch close event
11:15:49	22/1/18	Fearam's switch close event
10:06:21	20/1/18	Fearam's switch close event
10:06:21	20/1/18	Normal Priority
14:52:54	25/1/18	Day to day switch open event
14:52:55	25/1/18	Day to day release
14:52:56	25/1/18	Day to day switch close event
14:52:57	25/1/18	Fearam's switch open event
14:52:58	25/1/18	Normal Priority
14:52:59	25/1/18	Day to day switch open event
14:53:00	25/1/18	Day to day release
14:53:01	25/1/18	Day to day switch close event
14:54:28	25/1/18	Fearam's switch close event
14:54:29	25/1/18	Normal Priority
14:54:30	25/1/18	Fearam's switch close event
14:54:31	25/1/18	Normal Priority
14:54:32	25/1/18	Normal Priority

# OS2 SHEVTEC® Control Panel

The OS2 SHEVTEC Controller is an intelligent 24V dc control system designed to drive 2-wire 24V dc actuators in a smoke control and/or environmental ventilation system

Operating from a 230V ac 5A supply, the OS2 SHEVTEC controller can deliver up to 8A to drive 24v motorised actuators and magnetic catches. Battery backup is provided for continued operation after a mains supply failure. Each controller can be mounted locally to the devices or in a centralised location. Each controller can operate independently or be linked to others to produce a networked control system. The networked control system can operate standalone or be linked to a Building Management System (BMS)

## NETWORKED CONTROL SYSTEM

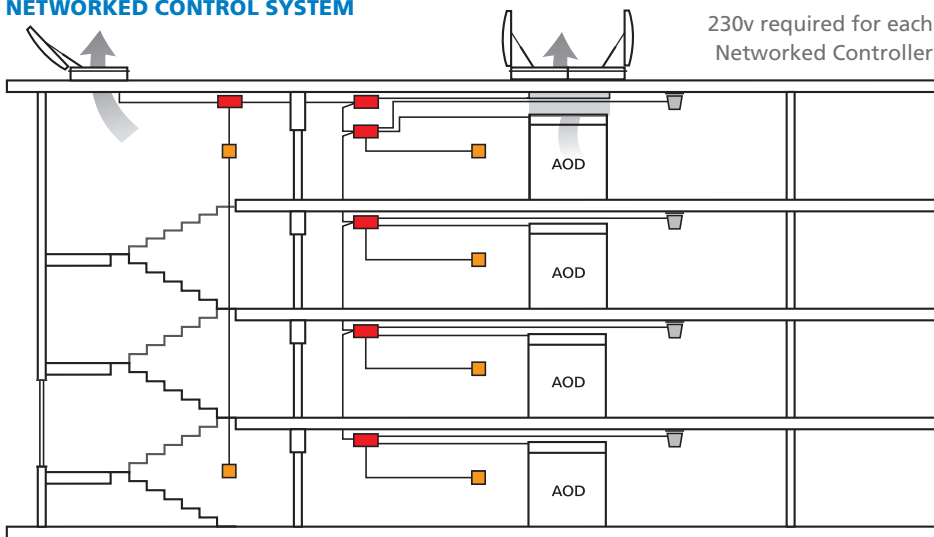

## CENTRALISED CONTROL SYSTEM

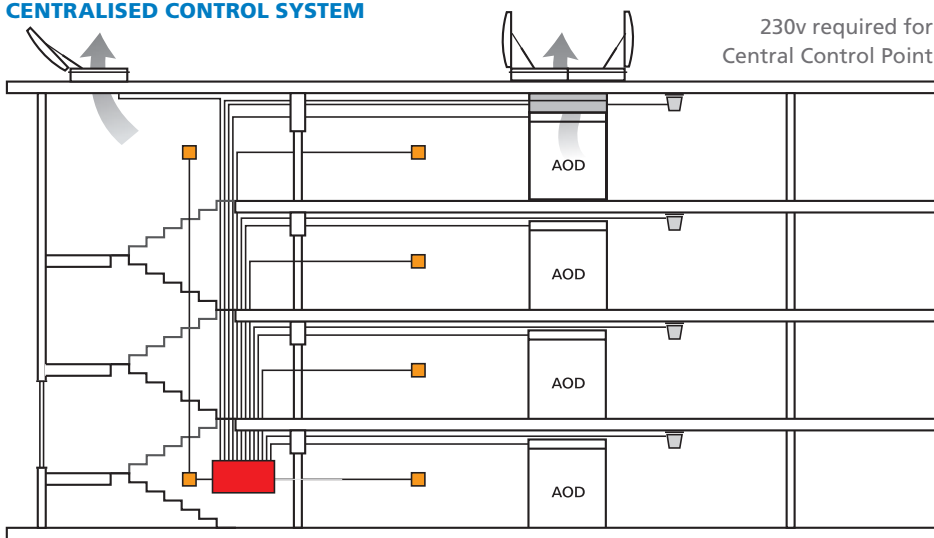

## APPLICATIONS

-  Smoke Ventilation
-  Environmental Ventilation

## ACCREDITATIONS

-  CE Certified Compliant to applicable regulations

## FINISH

-  Unit comes in a standard GREY Powder coated enclosure

**Key** ■ OS2 SHEVTEC Controller ☐ Optical Smoke Detector ■ Manual Control Point

# OSLoop Coordinator

OSLoop is a modular smoke control product that consists of a centralised coordination module and can control between 1 and 15 remotely mounted manual control points (MCPs). Larger systems can be constructed by linking together multiple coordinators, allowing the control of up to 64 MCPs.



The coordinator controls power and data to the networked system, fully monitoring primary (mains) and secondary (battery) power supplies. The OSLoop system intelligently monitors current requirements of the system and determines how and when the MCPs require power to activate the AOVs.

Each MCP contains actuator switching circuitry which also monitors the actuator cabling and circuitry for faults. If a fault is detected, then the MCP raises a local alarm and also signals the coordinator so the remote alarms can be triggered. The MCP also provides support for one or more smoke detectors and monitors the detectors and cabling, checking for faults. In addition the MCP can be configured as master/slave device to other MCPs in the same system.

- System power is delivered via the Manual Control Point reducing the power supply and cable requirements
- 40% less cable costs than a conventional system
- 50% less devices compared to conventional systems
- Reduced system installation time
- prEN12101-9 and EN12101-10
- EMC tested to EN61000-6-2 and EN61000-6-3
- LVD tested to EN60335-1 as amended by EN60335-2-103.

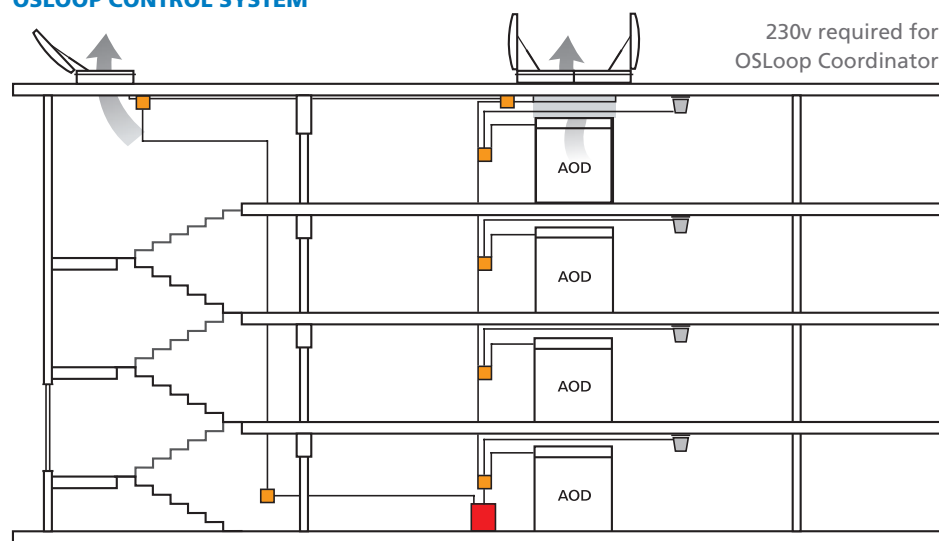
## OSLOOP CONTROL SYSTEM



**Key**  OSLoop Coordinator  Optical Smoke Detector  Manual Control Point



## APPLICATIONS



Smoke Ventilation

## ACCREDITATIONS



CE Certified  
Compliant to  
applicable regulations

## FINISH



Unit comes in a  
standard GREY Powder  
coated enclosure

# OS2 SHEVTEC<sup>®</sup> System Wiring

A	2 Core + Earth x 2.5mm <sup>2</sup> FP 200 Gold by others	E	4 Core + Screen x 1.5mm <sup>2</sup> FP 200 Gold by others
B	5 Core x 1.5mm <sup>2</sup> FP 200 Gold by others	F	Not Used
C	3 Core + Earth x 1.5mm <sup>2</sup> FP 200 Gold by others	G	2 Core + Earth x 1.5mm <sup>2</sup> LSF/ PVC cable by others
D	2 Core + Screen x 1.5mm <sup>2</sup> FP 200 Gold by others	H	3 Core + Earth x 1.5mm <sup>2</sup> LSF/ PVC cable by others



# OSLoop System Wiring

A	2 Core + Earth x 2.5mm <sup>2</sup> FP 200 Gold by others
B	4 Core + Earth x 2.5mm <sup>2</sup> FP 200 Gold by others
C	2 Core + Earth x 1.5mm <sup>2</sup> FP 200 Gold by others
D	4 Core + Screen x 1.5mm <sup>2</sup> FP 200 Gold by others
E	Not used



# SHEV Systems

SE Controls can provide a mechanical smoke ventilation system designed as an alternative solution to ADB and BRE smoke shafts.

Mechanical solutions can offer reduced smoke shaft sizes (typical 0.6m<sup>2</sup> versus 1.5m<sup>2</sup> or 3m<sup>2</sup>) increasing the lettable areas in a development. In addition, a mechanical system in conjunction with CFD modelled fire engineered solutions, offer increased escape travel distances reducing the need to include additional stair cores.

This type of system has been designed for both means of escape and fire fighting operation with occupants and fire & rescue service safety to the fore.

## EXTENDED ESCAPE TRAVEL DISTANCE SYSTEM

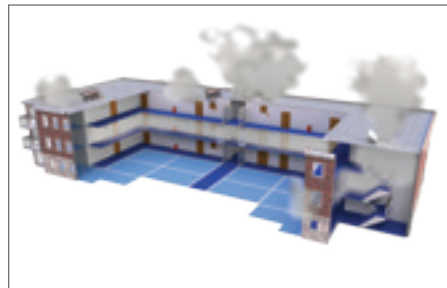

## CFD MODELLING ANALYSIS

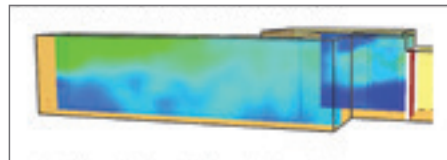
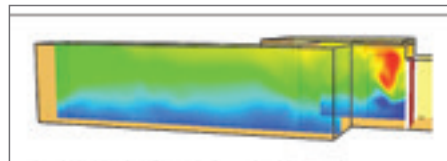

## THE EFFECT ON HALLWAYS BY RAPIDLY CLEARING SMOKE



## LOCATION OF PRODUCTS IN TYPICAL BUILDING

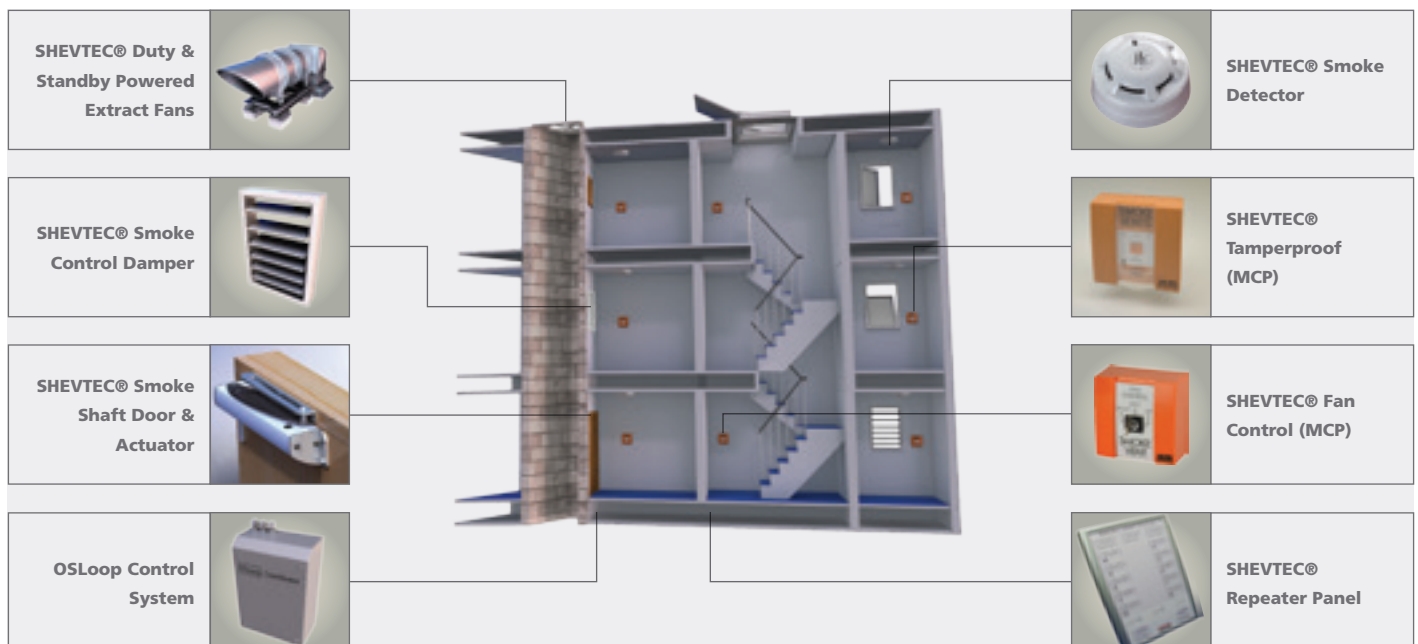

# Powered Fan Systems

Regardless of the structure and constraints of the available building space, SE Controls offer a range of solutions that can be tailored to meet all specifications

This includes mechanical extraction systems which can facilitate the need for smaller openings and a narrower shaft space, releasing valuable rentable floor space.

## TYPICAL SCHEMATIC

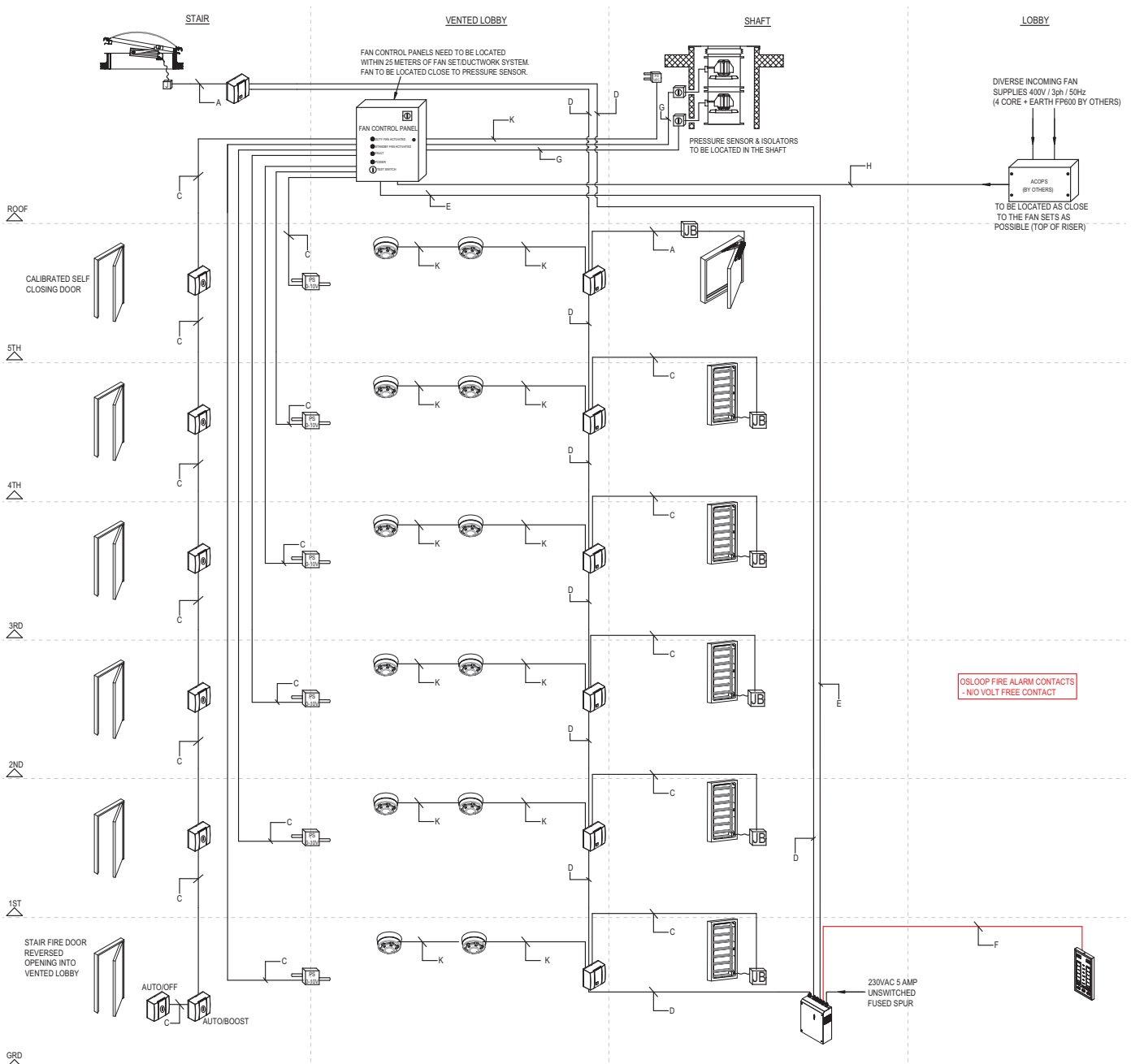

# NVLogiQ™ Indoor Air Quality

## HOW IT WORKS

NVLogiQ constantly monitors indoor air quality, temperature and humidity in individual rooms or zones.

By then applying innovative control algorithms, it automatically manages the operation of windows, louvres, rooflights and other powered vents in conjunction with heating & cooling systems to optimise indoor air quality and thermal comfort, while optimising energy efficiency.

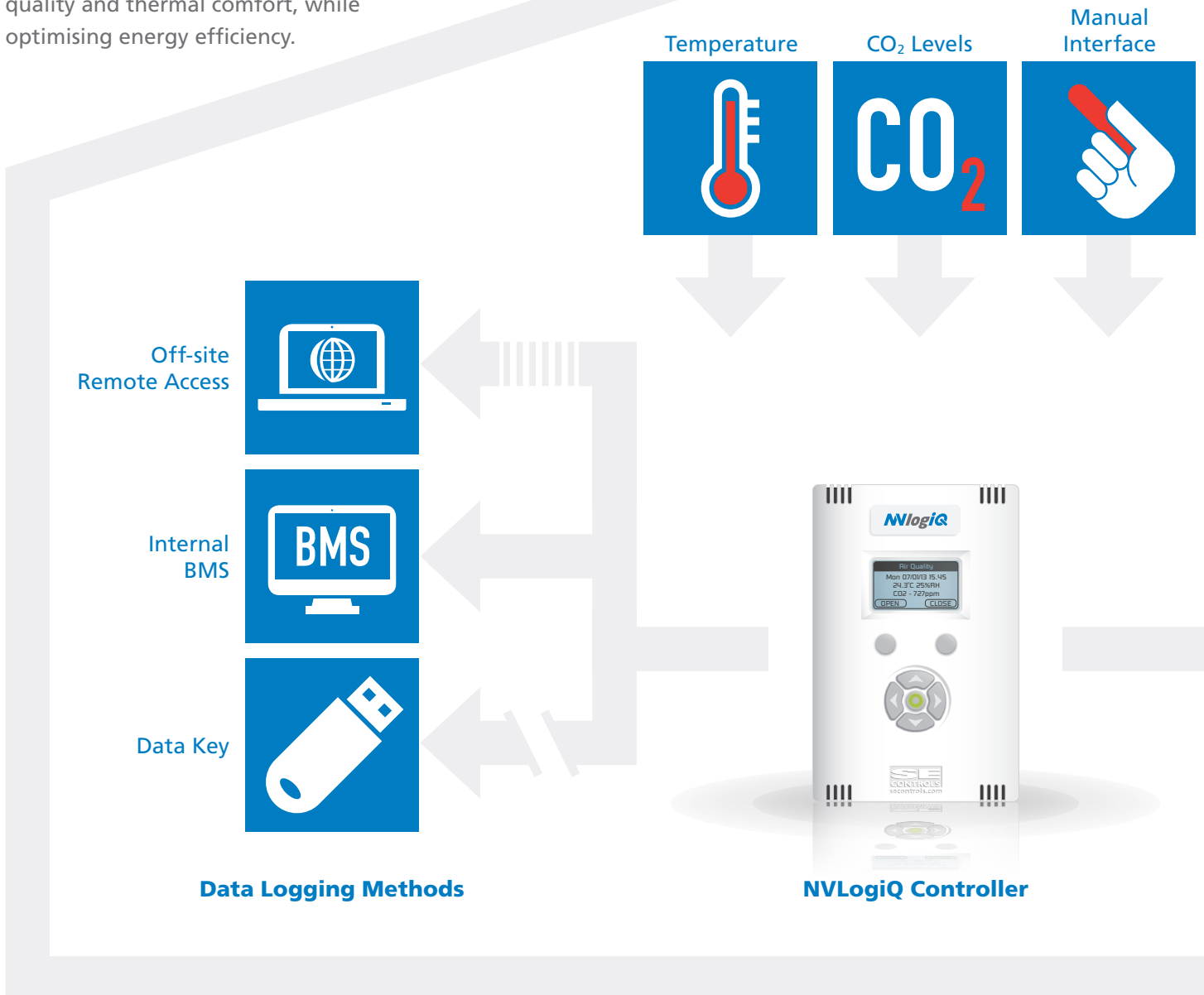

Example Air Flow Building Solutions

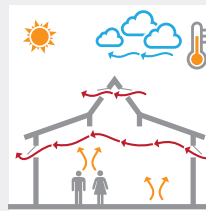

Cross Ventilation

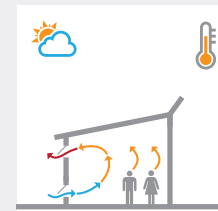

Single Sided Ventilation

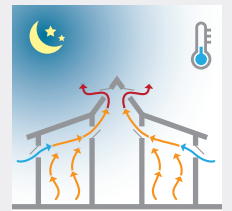

Night or Passive Cooling Ventilation

Obstruction Sensors



Rain Sensors



Temperature / Wind Sensor

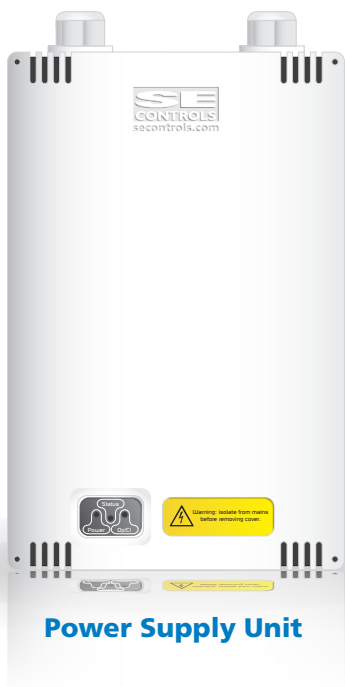
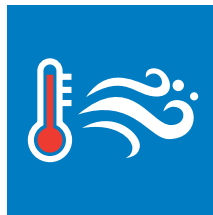

Power Supply Unit



Automatic Opening Vents



Fans & Cooling

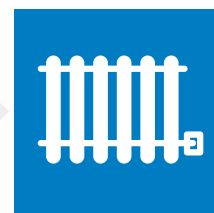

Heating Systems

Automated Control Units

# NVLogiQ™ Indoor Air Quality

Independent research has demonstrated that moderate levels of CO<sub>2</sub> have a negative impact on the cognitive functions of the inhabitants of a given environment.

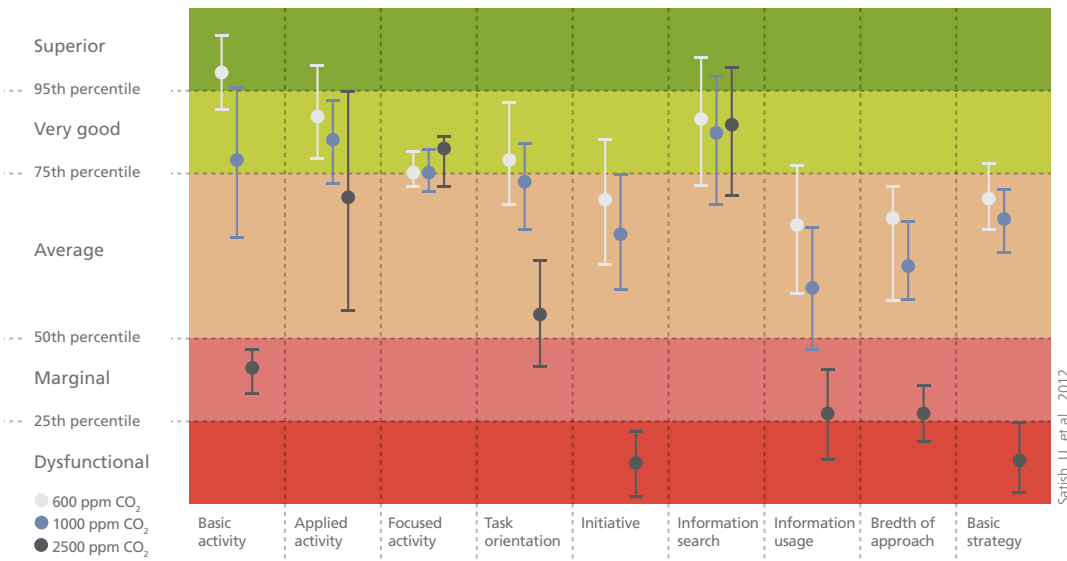

Satish, U., et al., 2012

## EFFECT OF NOT HAVING AUTOMATED CONTROL

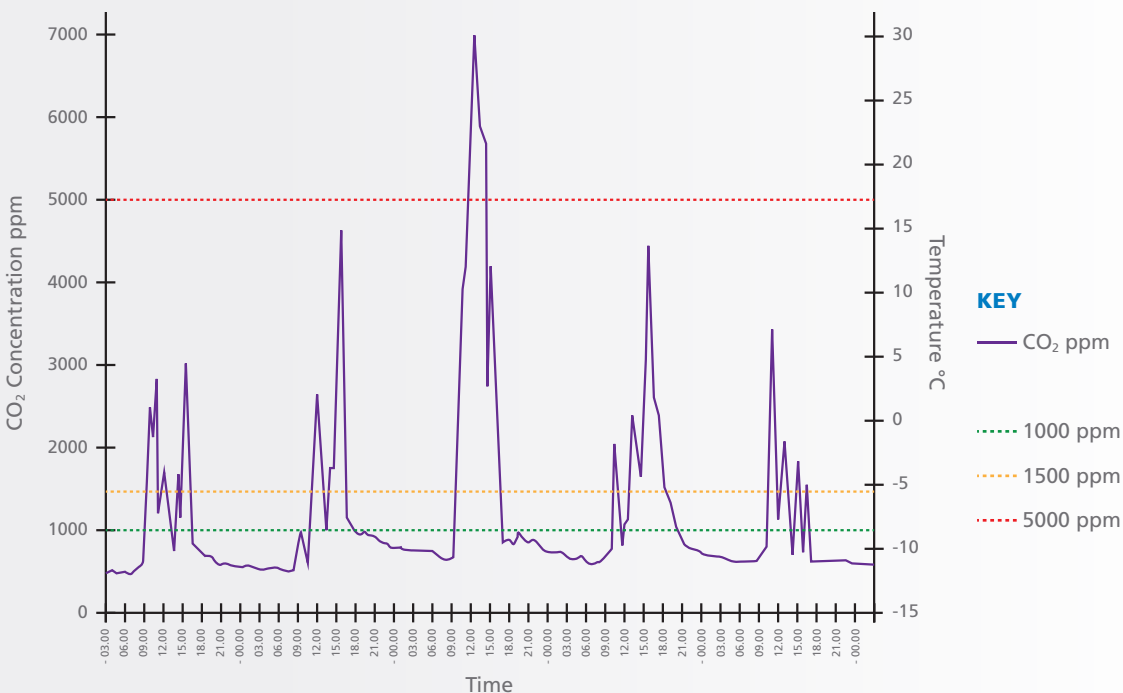

# NVLogiQ™ Room Controller

NVLogiQ allows remote monitoring of the installation and can be used to demonstrate the current room conditions over a period to several month to help justify the need for an automated system.

Once installed, the system can be used to monitor the current air quality and can be downloaded as an easy to read graph which shows a range of readings including CO<sub>2</sub>, temperature and vent position.

## REMOTE MONITORING AREAS

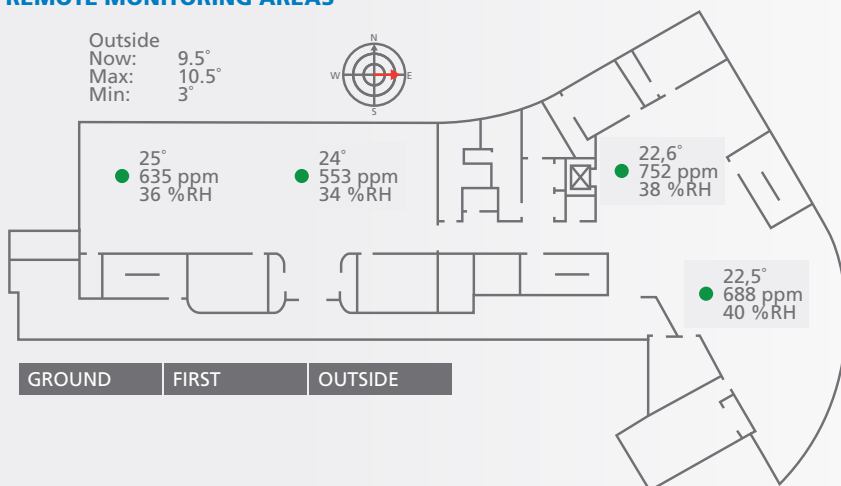

## EFFECT OF HAVING AUTOMATED CONTROLS

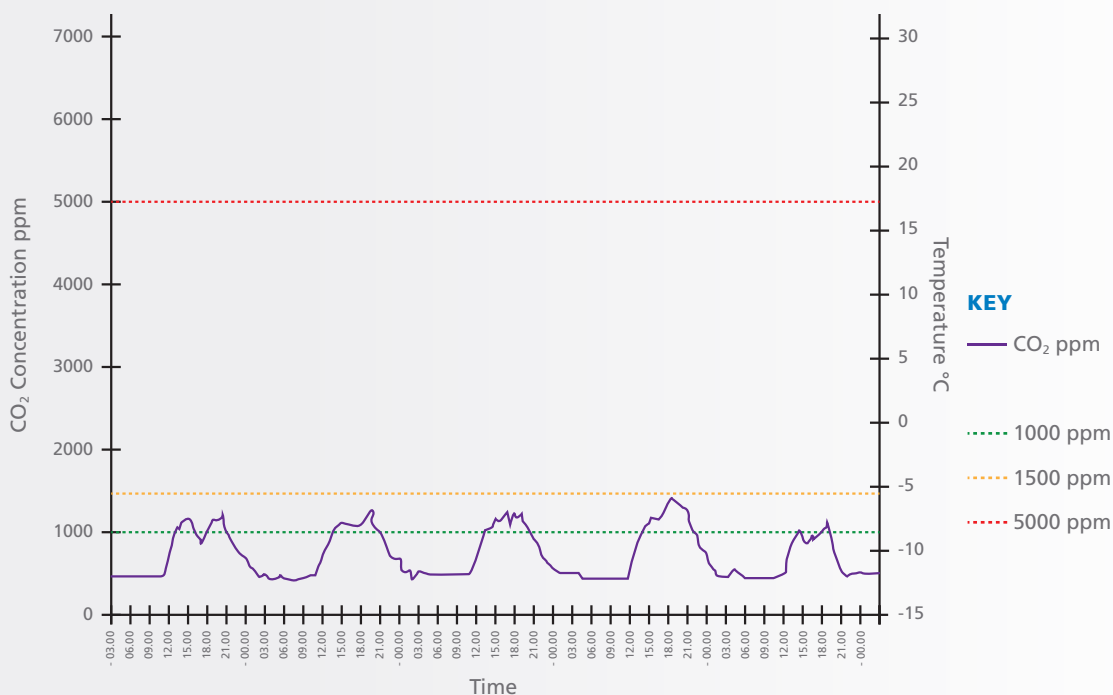

# Manual Winding Gear

## Simple, inexpensive solution for environmental ventilation.







The Kongsberg Automotive 'Clearline' (Originally Teleflex) system is designed for out of reach windows in all buildings/markets: commercial, education, healthcare, residential and domestic.

The system entails a chain opener operated via a winding handle linked together by conduit and cable. Winding handles can be positioned to allow easy opening of hard to reach locations, while operating multiple vents via a single winding handle with a maximum cable run of up to 18 metres. This surface mounted application offers greater flexibility and compatibility with almost all window systems.

### KEY FEATURES:

- Quality Engineered Stainless Steel Chain Openers.
- Up to 18m operation from Winding Handle to Chain Opener.
- Range of handle options to suit differing weight loads
- Low maintenance hard wearing system.
- Range of colours
- Product Manufactured in the UK.

### DETAILS

Window Orientation	Max Cable Length	Control Device	Window Size One Push Point
BHOO 	18m	Mini, Long Midi, Midi, Maxi	Up to Max 1100mm Wide. Min 250mm deep
THOO 	18m	Mini, Long Midi, Midi, Maxi	Up to Max 1100mm Wide. Min 250mm deep
Centre Pivot 	18m	Mini, Long Midi, Midi, Maxi	Up to Max 1100mm Wide. Min 250mm deep
Side Hung 	18m	Mini, Long Midi, Midi, Maxi	Up to Max 1100mm Wide. Min 250mm deep
BHOI 	18m	Mini, Long Midi, Midi, Maxi	Up to Max 1100mm Wide. Min 250mm deep. Min 45mm head clearance required.
Roof Vent 	20m	Long Midi, Midi, Maxi	Approx 20kg.

### COLOUR OPTIONS

WHITE	RAL 9010
BLACK	RAL 9005
BROWN	RAL 8017
GREY	RAL 9006

### CONFIGURATION OPTIONS

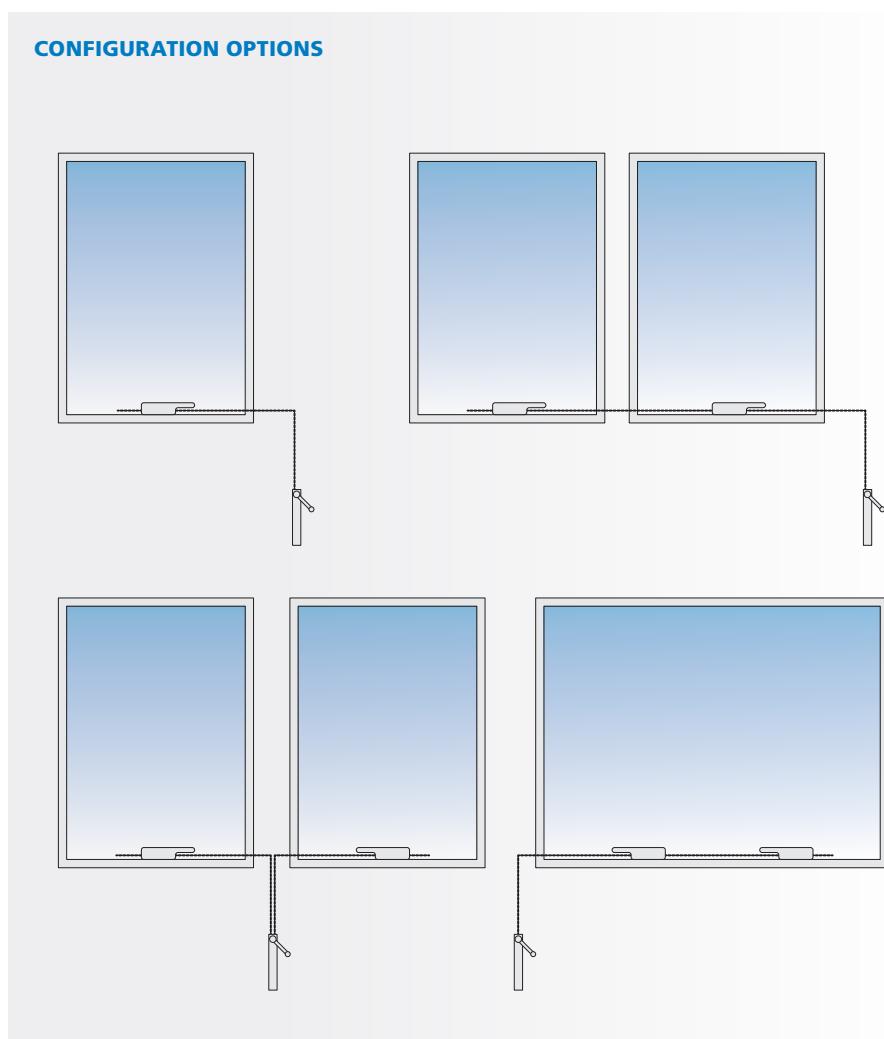

### ACCESSORIES

#### Core

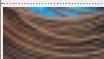
	1 x ROLL	EMK0010135C
---	----------	-------------

#### Connectors

	BLACK	EMK001018BL
	BROWN	EMK001018BR
	GREY	EMK001018GR
	WHITE	EMK001018WH

#### Conduit (3m lengths)

	BLACK	EMK001012BL
	BROWN	EMK001012BR
	GREY	EMK001012GR
	WHITE	EMK001012WH

#### Saddle Packer

	BLACK	EMK001016BL
	BROWN	EMK001016BR
	GREY	EMK001016GR
	WHITE	EMK001016WH

#### Saddle Clip

	BLACK	EMK001015BL
	BROWN	EMK001015BR
	GREY	EMK001015GR
	WHITE	EMK001015WH

#### Saddle Base

	WHITE	EMK0010145C
---	-------	-------------

### BRACKETS

#### Fixing Plate 002 Metal

	BLACK	EBT00010002
	BROWN	EBT00010004
	GREY	EBT00010003
	WHITE	EBT00010001

#### Fixing Plate 004 Wood/PVC

	BLACK	EBT00020002
	BROWN	EBT00020004
	GREY	EBT00020003
	WHITE	EBT00020001

#### Open Inward Bracket

	BLACK	EBT00030002
	BROWN	EBT00030004
	GREY	EBT00030003
	WHITE	EBT00030001

### SCREW JACK OPENER

	EMK001008W2
--	-------------

### CHAIN OPENER

250mm		
	BLACK	EMK001006BL
	BROWN	EMK001006BR
	GREY	EMK001006GR
	WHITE	EMK001006WH
380mm		
	BLACK	EMK001007BL
	BROWN	EMK001007BR
	GREY	EMK001007GR
	WHITE	EMK001007WH

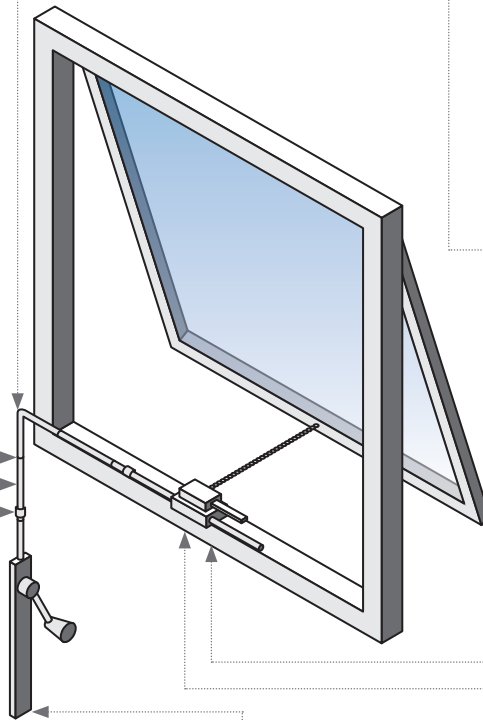

### OPERATING HANDLES

#### Long Midi Operator

	BLACK	EMK01001BLL
	BROWN	NA
	GREY	EMK01001GRL
	WHITE	EMK01001WHL

#### Midi Operator

	BLACK	EMK001001BL
	BROWN	EMK001001BR
	GREY	EMK001001GR
	WHITE	EMK001001WH

#### Maxi Operator

	BLACK	EMK001000BL
	BROWN	EMK001000BR
	GREY	EMK001000GR
	WHITE	EMK001000WH

#### Mini Operator

	BLACK	EMK001002BL
	BROWN	EMK001002BR
	GREY	EMK001002GR
	WHITE	EMK001002WH

#### 100mm Handle

	BLACK	EMK001003BL
	BROWN	EMK001003BR
	GREY	EMK001003GR
	WHITE	EMK001003WH

# OS2 SHEVTEC<sup>®</sup> Controller

## POWER

- Supply: 230V ac 50/60 Hz from a 5A fused unswitched spur
- Output: nominal 24V dc 2-Channels combined output not to exceed 8A
- Backup battery: 2 x 12 V dc 7.0Ah sealed lead-acid batteries
- Battery standby time: 72 hours with maximum 40mA standby drain on PER permanent\*
- Expected battery life: 3+ years @ 25°C
- Real time clock battery life: 10 years

## ENVIRONMENT

- IP 30
- Humidity range: 10 to 90% Non-condensing
- Storage: -20 to +50°C
- Operating temperature for Control Panel (not including batteries): -5 to 40°C\*\*

## MISCELLANEOUS

- Dimensions: 364.5 x 337.8 x 128.4mm
- Mass: approx 13kg
- Cable entry: via 15 x 20mm end mounted cable glands and/or one rear entry slot for concealed connection
- Internal temperature sensor installed to provide optimal battery charging compensation as the ambient temperature changes.

\*Standby drain current comprises of enabled fire inputs, communication cards, and other loads connected to PER.

\*\*Operation at elevated temperatures may reduce battery life.

## PRODUCT CODES

OS2 SHEVTEC Controller	FCS12250000
------------------------	-------------



## TECHNICAL DRAWING

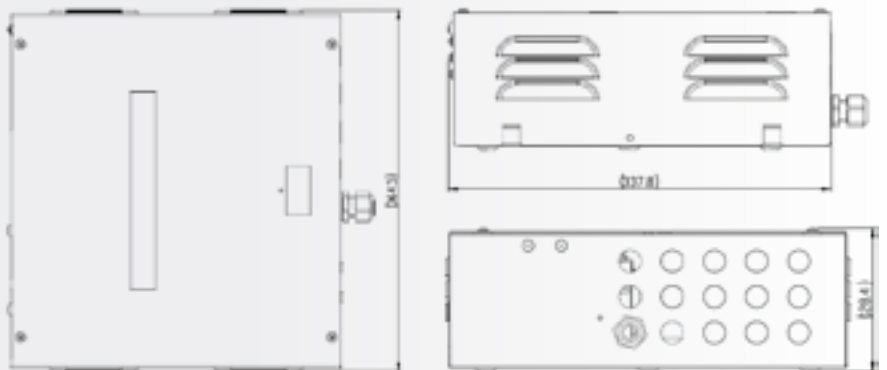

## APPLICATIONS



Smoke Ventilation



Environmental Ventilation

## ACCREDITATIONS



Certified & tested in accordance with EN12101-10

# OS2 SHEVTEC® 30A PSU

## POWER

- Supply: 230V ac 50/60 Hz from a 13A supply
- Output: Nominal 24V dc 4-channels output not to exceed 8A per channel
- Back up battery: 2 x 12V dc 22.0Ah sealed lead-acid batteries
- Battery standby time: 72 hours with maximum 100mA standby drain on PER permanent\*
- Expected battery life: 3+ years @ 25°C
- Real time clock battery life: 10 years
- 110/230V input

## ENVIRONMENT

- IP 30
- Humidity rating: 10-90% Non-condensing
- Storage: -20 to +50°C
- Operating temperature for control panel (not inc. batteries): -5 to +40°C\*\*

## MISCELLANEOUS

- Dimensions: 600x400x250mm
- Mass: Approx with batteries 33.4kg, without batteries 20.2kg
- Cable entry: Via 32x20mm top mounted cable glands
- Internal temperature sensor installed to provide optimal battery charging compensation as the ambient temperature changes
- \*Standby drain current comprises of enabled fire inputs, communication cards and other loads connected to PER
- \*\*Operation at elevated temperatures may reduce battery life

## PRODUCT CODES

30A PANEL with battery backup  
Part Number: FCS12001030

Without battery backup

Part Number: FCS12000031



## TECHNICAL DRAWING



## APPLICATIONS



Smoke Ventilation



Environmental Ventilation

## ACCREDITATIONS



Certified & tested in accordance with EN12101-10

# OSLoop Control System

## FEATURES

- 40% less cable costs than a conventional system
- 50% less devices compared to conventional systems
- Reduced system installation time
- prEN12101-9 and fully EN12101-10 compliant
- EMC tested to EN61000-6-2 and EN61000-6-3
- LVD tested to EN60335-1 as amended by EN60335-2-103.

## COORDINATOR SPECIFICATION

Part number	FCS00300010
Dimensions	310 x 380 x 130mm (W x H x D Approx.)
Mass Approx	4.1kg
Supply	230V AC, 50/60Hz @ 4A
Output VA	25.5VDC @7A continuous, 9A for 60 seconds
Output VB	27.6VDC @7A continuous, 10A for 60 seconds
VB Batteries	2x12VDC 12.0Ah Sealed Lead-Acid Batteries. (Operation at elevated temperatures may reduce battery life)
IP Rating	IP20
Humidity	10 to 90% Non-Condensing
Temperatures	20 to + 75°C (storage) 0 to +40°C (operating)

## MANUAL CONTROL POINT (MCP) SPECIFICATION

Standard MCP Part numbers	FCS00300027 (Complete unit) FYS15040061 (Surface mounted pattress box)
Tamperproof MCP Part Numbers	FCS00300028 (Complete unit) FYS15040061 (Surface mounted pattress box)
Dimensions	87 x 87 x 50mm (H x W x D Approx.)
Mass Approx	0.1kg
Supply	20V-29V DC @ 4A
Output	20V-29V @6A Max
IP Rating	IP20
Humidity	10 to 90% Non-Condensing
Temperatures	20 to + 75°C (storage) 0 to +50°C (operating)

## SMOKE DETECTOR SPECIFICATION

Part numbers	HEAD PART NO. ADA 55000318 OSLoop BASE PART NO. ADA 45681200
	FasTest takes just 4 seconds to test and confirm detectors are functioning correctly
	Responds well to slow-burning, smouldering fires
	Good performance in both black and white smoke

## APPLICATIONS



Smoke Ventilation

## ACCREDITATIONS

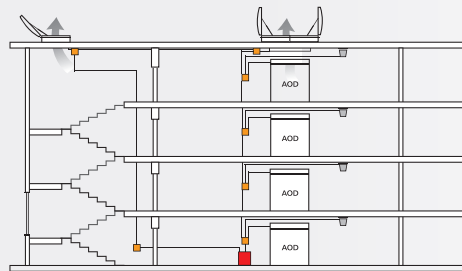

## KEY

- OSLoop Coordinator
- Optical Smoke Detector
- Manual Control Point

## TECHNICAL DRAWING

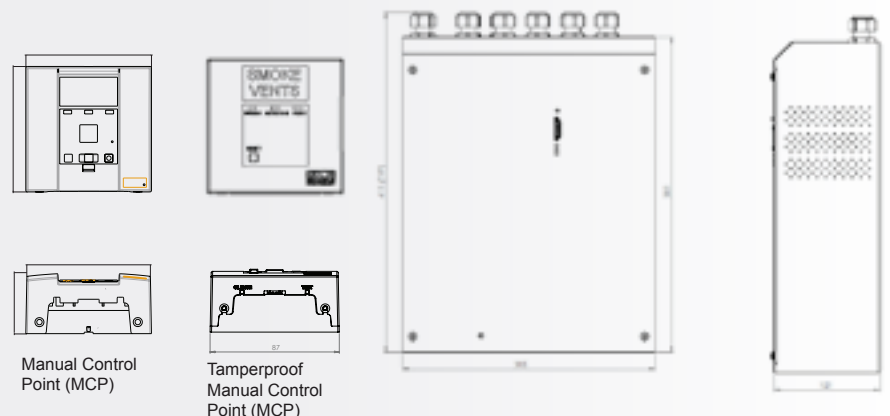

# Smoke Detector

## DETECTOR OPERATING PRINCIPLES

Principle of detection: Photo-electric detection of light scattered by smoke particles over a wide range of angles. The optical arrangement comprises an infra-red emitter with a prism and a photo-diode at 90° to the light beam with a wide field of view.

## DETAILS

- Flashing LED: The integral LED flashes when the detector is in a quiescent state.
- Supply Voltage: 9 to 33V DC
- Ripple Voltage: 2V peak to peak max at 0.1Hz to 100kHz
- Power-up Time: <20 seconds
- Alarm Current: 40mA
- Material: Detector and base moulded in white polycarbonate
- Terminals: Nickel plated stainless steel
- Dimensions: Detector 100 x 42mm, Detector in Base 100 x 50mm
- Weight: Detector 99g Detector in base 150g
- Temperature: Operating temperature -20°C to +60°C (no condensation or icing)
- Humidity: 0% to 95% relative humidity (no condensation)
- Atmospheric Pressure: Insensitive to pressure
- Wind Speed: Insensitive to wind
- IP 23

## PART NUMBERS

- HEAD PART NO. ADA 55000318
- OS2 BASE PART NO. ADA 45681245
- OSLoop BASE PART NO. ADA 45681200

## APPLICATIONS



Smoke Ventilation

## ACCREDITATIONS



# Tamper Proof Manual Control Point (MCP)

## DETAILS

- prEN12101-9
- Provided in orange (RAL 2011) as required as part of prEN12101-9
- The device has the capabilities to provide audible signals and faults along with having a silence button out of view
- The device continuously monitors actuators and connections to smoke detectors (As required as part of prEN12101-9)
- Event logging to provide historical user information
- Maintenance indication (Statutory requirement of the Regulatory Reform Order (Fire Safety))
- Activation via access key fob
- Reset via access key fob
- Reset push button
- Activated LED
- Power/Healthy LED
- Fault LED

## FOR USE WITH 24V OSLOOP AND OS2 CONTROL PANELS

- 87 x 87 x 22mm (h x w x d) - Flush mount
- 87 x 87 x 54mm (h x w x d) - Surface mount

## MCP PART NUMBERS

OSLoop MCP part number	Complete Unit	FCS00300028
OS2 MCP part numbers	MCP Module	FCS00200081
	Dumb Reset Key	FCS00200024
	MCP Activation Key	FCS00200033
	Surface Mount Box	FYS15040061



## TECHNICAL DRAWING



## OSLOOP CONTROL SYSTEM

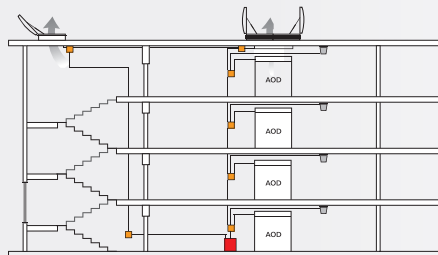

## OS2 CONTROL SYSTEM

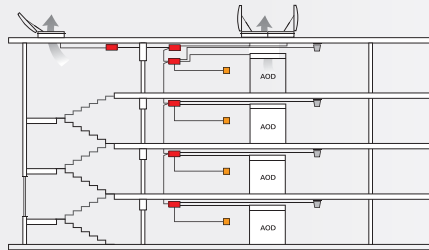

## KEY

- OSLoop Coordinator
- Optical Smoke Detector
- Manual Control Point

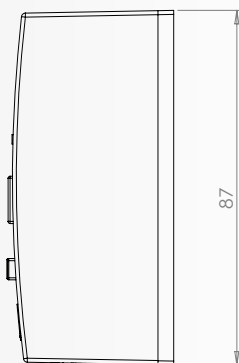
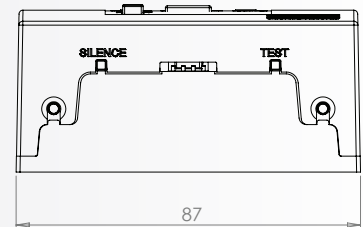

## APPLICATIONS



Smoke Ventilation

## ACCREDITATIONS



# Manual Control Point (MCP)

## DETAILS

- prEN12101-9
- Provided in orange (RAL 2011) as required as part of prEN12101-9
- The device has the capability to provide audible signals and faults along with having a silence button out of view
- The MCP (OSLoop version) continuously monitors actuators and connections to smoke detectors (As required as part of prEN12101-9)
- Event logging to provide historical user information
- Maintenance indication (Statutory requirement of the Regulatory Reform Order (Fire Safety))
- Cover reset push button via access key fob
- Reset push button
- Activated LED
- Power/Healthy LED
- Fault LED
- Single action activation cover (replaces glass frangible element)

## FOR USE WITH 24V OSLOOP AND OS2 CONTROL PANELS

- 87 x 87 x 22mm (h x w x d) - Flush mount
- 87 x 87 x 54mm (h x w x d) - Surface mount

## MCP PART NUMBERS

OSLoop MCP part number	Complete Unit	FCS00300027
OS2 MCP part numbers	MCP Module	FC500200080
	Dumb Reset Key	FCS00200024
	Surface Mount Box	FYS15040061
	MCP Finger Plate	FCS00200055



## TECHNICAL DRAWING



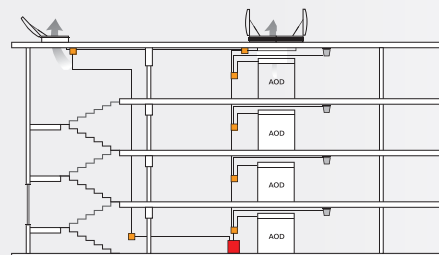

## OSLOOP CONTROL SYSTEM

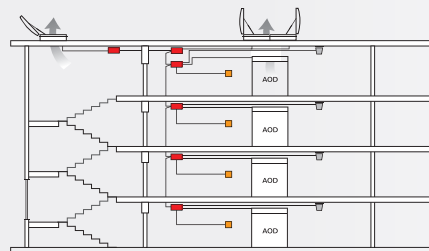

## OS2 CONTROL SYSTEM



## KEY

-  OSLoop Coordinator
-  Optical Smoke Detector
-  Manual Control Point

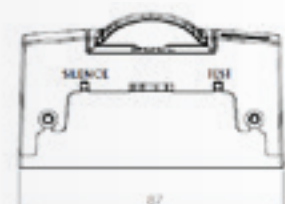

## APPLICATIONS



Smoke Ventilation

## ACCREDITATIONS



# NVLogiQ™ Room Controller

## FEATURES

The NVLogiQ™ Room Controller has been designed to offer an effective, efficient and user friendly solution for adaptive environmental ventilation applications that is easily integrated into a new or refurbished building.

The NVLogiQ™ Room Controller can be used as a standalone system or networked to give individual room control with global common signals such as wind, rain and security closing.

All within a small wall-mounted enclosure, the NVLogiQ™ Room Controller has integrated sensors, switches and a backlit LCD display that offers the following facilities without the need for separate sensors within the room:

- CO<sub>2</sub> monitoring and level display
- Temperature monitoring and level display
- Humidity monitoring and level display
- User control via inbuilt switches with ten increments of operation
- Output signal for external devices such as central heating control etc
- Lock out function to prevent misuse
- Time clock for strategy and security closing
- Vent position/open output signal
- Fresh air 'morning start' setting
- Intuitive menu for setpoint adjustment via a security dongle
- Continuous data logging for performance analysis

The NVLogiQ™ Room Controller is supplied with a pre-programmed natural ventilation control algorithm developed in partnership with Loughborough University's Building Energy Research Group.

The strategy was formulated by modelling hundreds of comparable scenarios in both education and commercial buildings in conjunction with industry recognised methods and data collected from environmental ventilation projects installed over several years by SE Controls.

Requirements for regulations such as BB101 (internal environment for schools) and CIBSE Guides A have heavily influenced the design of the algorithms.

Dynamic Thermal Simulation models (DTS) and Computational Fluid Dynamics (CFD) were used to analyse the effectiveness and efficiency of the algorithm.

The system controls room CO<sub>2</sub> levels to a variable profile ensuring that indoor Air Quality (IAQ) is optimised. The temperature control strategy increases the ventilation rate before internal temperature escalates and becomes uncontrollable. There are multiple temperature control strategies based on external temperature, and occupancy, which provide appropriate temperature control throughout the year.

A night purge strategy cools the building for a fresh start and can provide prolonged daytime cooling in buildings with sufficient thermal mass.

All settings are adjustable from standard or after the initial 'learning' period of occupancy.

Data logging is essential for pre or post occupancy performance analysis; the controller is capable of 3 month's recording of sensor readings and operation signals, and is downloadable using a dongle.

## APPLICATIONS



Environmental Ventilation

## ACCREDITATIONS

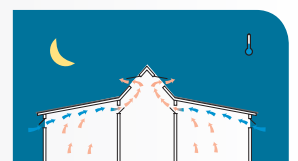
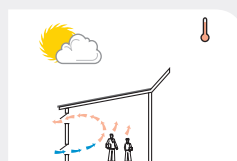

## DETAILS

### POWER

- Class 1
- Supply: Input: 24v DC
- Output: 0-10v and OSLink
- Real time clock battery average life 10 years

### ENVIRONMENT

- Rating: IP20
- Humidity Range: 10 to 90% non-condensing
- Storage: -20 to +50°C
- Operating temp: -10 to +50°C

### MISCELLANEOUS

- Dimensions: 160 x 105 x 37 mm. Dia. 20mm top entry with cap and 58mm x 36mm rear entry

## PART NUMBERS

NVLogiQ™ with CO<sub>2</sub>

Part Number: NCS00020001

NVLogiQ™ without CO<sub>2</sub>

Part Number: NCS00020002

# NVLogiQ™ PSU

## TECHNICAL DATA

### POWER

- Class 1
- Supply: 230V ac 50/60 Hz from a fused un-switched spur
- Input: 100-120VAC 3.5A / 200-240VAC 2.0A
- Note: For 115VAC operation, the mains input voltage selection switch must be set on the internal power supply.
- Output: 6A max actuator run current
- Note: Start up peak current needs to be considered and can vary depending on actuator type. Derate linearly to 70% load from +50 to +70°C.
- Real time clock battery average life 10 years

### ENVIRONMENT

- IP20
- Humidity Range: 10 to 90% Non-Condensing
- Storage: -20 to + 75 °C
- Operating temp: -10 to + 50 °C

### MISCELLANEOUS

- Dimensions: 251.15 (excluding glands) x 191.2 x 56.3mm
- Cable entry: via five 20mm end mounted cable glands
- 0-10 Volts signals must remain stable and 'spike' free for a period of 2 seconds before the controller will respond to them. In 10% step mode, the controller only responds to 0-10V signals in steps of whole volts 250mV. In 5% step mode, each step is half a volt.

## PART NUMBERS

- NVLogiQ PSU CONTROL PANEL 6A  
Part Number: NPS00010002



## TECHNICAL DRAWING

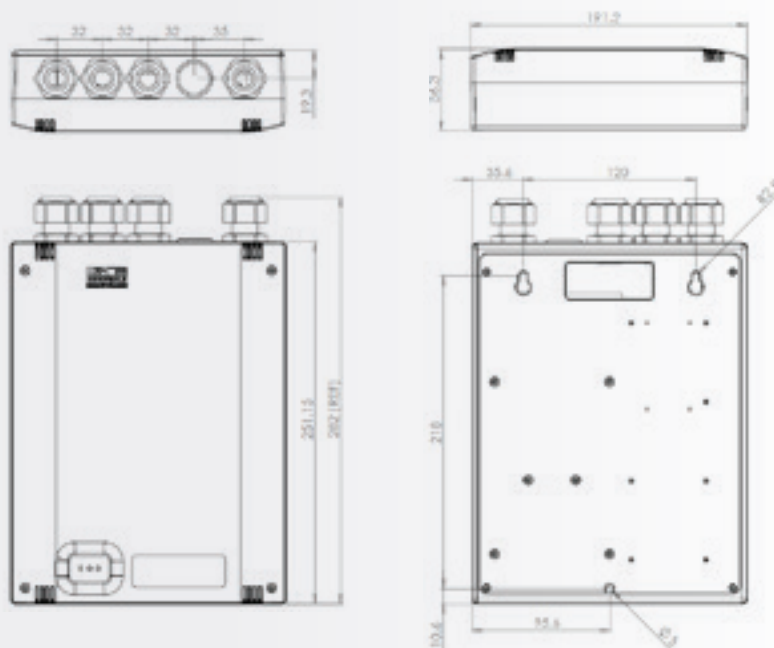

## APPLICATIONS



## ACCREDITATIONS



# 3A Transformer- Fascia Switched

## DETAILS

The SE Controls 230V 3A Transformer is a reverse polarity transformer designed to drive 2-wire 24V dc actuators in a environmental ventilation system.

This touch sensitive capacitive switch is a cost effective control mechanism that fits neatly into a standard double gang aperture.

## TECHNICAL DATA

Voltage	230V ac / 50/60Hz (+/- 10%)
Power Consumption	Max 350mA
Fuses	1Amp
Voltage Output	24V +/-10%
Output Current	Max. 3Amp
Duty Cycle	1 min on/ 4 min off
Ingress Protection	IP50 din 40050
Housing	plastic, white for surface mounting
Dimensions	approx. 146 x 86 x 40mm ( w x h x d)
Ambient Temperature	0-40°C
Connecting Terminal	230V max. 1.5mm <sup>2</sup>
	24V max. 1.5mm <sup>2</sup>
Application	Environmental

## PART NUMBERS

Product	Part No
3A Transformer - Fascia switched	FR500010032

\*The product is to be fitted into a compatible MK manufactured double pattress box, with minimum depth of 47mm.

## APPLICATIONS



Environmental Ventilation

## ACCREDITATIONS



## TECHNICAL DRAWING

Typical Connection Details:

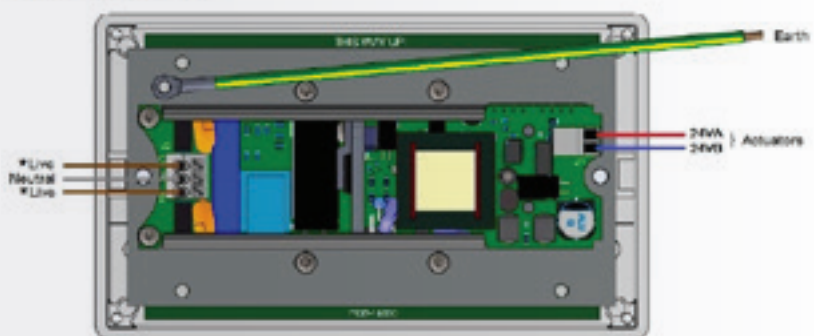

\*Live can be connected to either L1 or L2 inputs

# 3A Transformer - Unswitched

## DETAILS

The SE Controls 230V 3A Transformer is a reverse polarity transformer designed to drive 2-wire 24V dc actuators in a environmental ventilation system.

A cost effective control mechanism that fits neatly into a standard double gang aperture.

## TECHNICAL DATA

Voltage	230V ac / 50/60Hz (+/- 10%)
Power Consumption	Max 350mA
Fuses	1Amp
Voltage Output	24V +/-10%
Output Current	Max. 3Amp
Duty Cycle	1 min on/ 4 min off
Ingress Protection	IP50 din 40050
Housing	plastic, white for surface mounting
Dimensions	approx. 146 x 86 x 40mm ( w x h x d)
Ambient Temperature	0-40°C
Connecting Terminal	230V max. 1.5mm <sup>2</sup>
	24V max. 1.5mm <sup>2</sup>
Application	Environmental

## PART NUMBERS

Product	Part No
3A Transformer - Unswitched	FRS00010031

\*The product is to be fitted into a compatible MK manufactured double pattress box, with minimum depth of 47mm.

## APPLICATIONS



Environmental Ventilation

## ACCREDITATIONS



## TECHNICAL DRAWING

### Typical Connection Details:

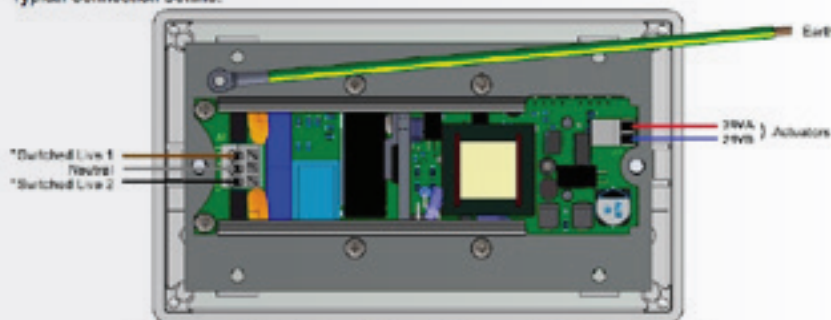

\*Connecting Live to both L1 and L2 inputs simultaneously will disable the output

# SECO Ni 24 40

## TECHNICAL DATA

Actuator	SECO Ni 24 40
Actuator Type	24V dc Chain Opener
Voltage (All +/-5%)	24V dc
Current Draw (Amp)	0-600mm= 1.0A 601-900mm= 1.2A
Stroke	0-600mm (configurable) 601-900mm (configurable)*
Operating Speed	15mm/sec min. 5mm/sec (configurable)
Ambient Operating Temp	-5°C to +60°C
Thrust Force	400N
Close Force	400N
Soft Close	Yes
Switching	Electronic
Standard Finish	Powder coated Grey (RAL 9006)
Seal Relief	Programmable up to 20mm
Clamping Force	4000N
Colour Option	Other RAL colours available on request
Flex Length	2m
Flex Type	2 core/ 0.75mm silicone 4 core (voltage free contact) as option
Flex Colour	Grey
Product Warranty	15,000 cycles
Duty Cycle	22% (2 mins on, 7 mins off)
Protection Degree	IP20
Bracket	Sill fixing/ open inward/ face fix bracket
Synchronisation	Optional
Application	Smoke and Environmental Ventilation

## DIMENSIONS

DIM X (mm)	STROKE (mm)
635	up to 600
785	601-900

## APPLICATIONS



Smoke Ventilation



Environmental Ventilation

## ACCREDITATIONS



Certified & tested in accordance with EN12101-2



## TECHNICAL DRAWING

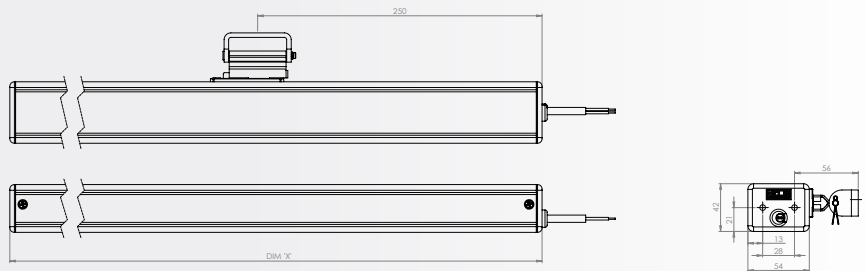

## PRODUCT CODES

SILVER GREY (RAL 9006)	OPERATING VOLTAGE	FORCE	STROKE
AASI4006005	24V	400N	600mm
AASI4009005	24V	400N	900mm

## BRACKET PRODUCT CODES

Height (mm)	Offset (mm)					
	0	5	8	10	15	20
35	AKS16000001	AKS16050001	AKS16080001	AKS16100001	AKS16150001	N/A
40	AKS16000002	AKS16050002	AKS16080002	AKS16100002	AKS16150002	N/A
50	AKS16000003	AKS16050003	AKS16080003	AKS16100003	AKS16150003	AKS16200003

# Twin SECO Ni 24 40

## TECHNICAL DATA

Actuator	Twin SECO Ni 24 40
Actuator Type	24V dc Chain Opener
Voltage (All +/-5%)	24V dc
Amp Draw Current (With Load)	0-600mm= 2.0A 601-900mm= 2.4A
Stroke	0-600mm (configurable) 601-900mm (configurable)*
Operating Speed	15mm/sec min. 5mm/sec (configurable)
Ambient Operating Temp	-5°C to +60°C
Thrust Force	2 x 400N
Close Force	2 x 400N
Soft Close	Yes
Switching	Electronic
Standard Finish	Powder coated Grey (RAL 9006)
Seal Relief	Programmable up to 20mm
Clamping Force	4000N
Colour Option	Other RAL colours available on request
Flex Length	2m
Flex Type	2 core/ 0.75mm silicone 4 core (volt free contact) as option
Flex Colour	Grey
Product Warranty	15,000 cycles
Duty Cycle	22% (approx. 2 mins on, 7 mins off)
Protection Degree	IP20
Bracket	Sill fixing/ open inward/ face fix bracket
Synchronisation	Optional
Application	Smoke and Environmental Ventilation

## DIMENSIONS

DIM X (mm)	DIM Y (mm)	STROKE (mm)
1295.5	753.5	up to 600
1592.5	1050.5	601-900



## TECHNICAL DRAWING

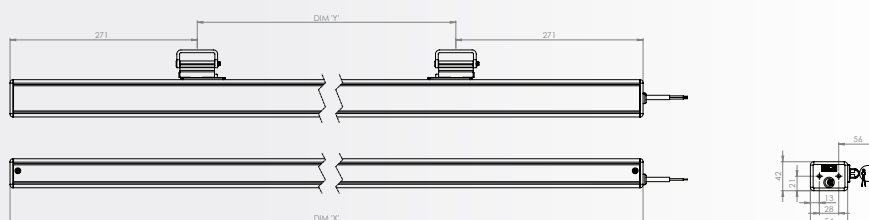

## PRODUCT CODES

SILVER GREY (RAL 9006)	OPERATING VOLTAGE	FORCE	STROKE
AAST140600S	24V	2 x 400N	600mm
AAST140900S	24V	2 x 400N	900mm

## BRACKET PRODUCT CODES

Height (mm)	Offset (mm)					
	0	5	8	10	15	20
35	AKS16000001	AKS16050001	AKS16080001	AKS16100001	AKS16150001	N/A
40	AKS16000002	AKS16050002	AKS16080002	AKS16100002	AKS16150002	N/A
50	AKS16000003	AKS16050003	AKS16080003	AKS16100003	AKS16150003	AKS16200003

## APPLICATIONS



## ACCREDITATIONS



# SECO N 24 25

## TECHNICAL DATA

Actuator	SECO N 24 25
Actuator Type	24V dc Chain Opener
Voltage (All +/-5%)	24V dc
Current Draw (Amp)	<0.5A
Stroke	250mm, 350mm (configurable)
Operating Speed	5mm/sec (configurable) 3mm/sec (option single application only)
Ambient Operating Temp	-5°C to +60°C
Thrust Force	250N
Close Force	250N
Soft Close	Yes
Switching	Electronic
Standard Finish	Powder coated Grey (RAL 9006)
Seal Relief	Programmable up to 20mm
Clamping Force	4000N
Colour Option	Other RAL colours available on request
Flex Length	2m
Flex Type	2 core PVC 4 core (volt free contact)* as option
Flex Colour	Grey
Product Warranty	15,000 cycles
Duty Cycle	22% (approx. 2 mins on, 7 mins off)
Protection Degree	IP20
Bracket	Sill fixing/ face fix/ thru body sill
Synchronisation	Optional
Application	Environmental Ventilation

## PRODUCT CODES

SILVER GREY (RAL 9006)	OPERATING VOLTAGE	FORCE	STROKE
AA502502505	24V	250N	250mm
AA502503505	24V	250N	350mm

## APPLICATIONS



Environmental Ventilation

## ACCREDITATIONS



## STANDARD BRACKET DETAIL



## TECHNICAL DRAWING



## BRACKET PRODUCT CODES

Height (mm)	Offset (mm)					
	0	5	8	10	15	20
35	AKS1800001	AKS1805001	AKS1808001	AKS1810001	AKS1815001	N/A
40	AKS1800002	AKS1805002	AKS1808002	AKS1810002	AKS1815002	N/A
50	AKS1800003	AKS1805003	AKS1808003	AKS1810003	AKS1815003	AKS1820003

# Twin SECO N 24 25

## TECHNICAL DATA

Actuator	Twin SECO N 24 25
Actuator Type	24V dc Chain Opener
Voltage (All +/-5%)	24V dc
Amp Draw Current	<1.0A
Stroke	350mm other strokes are available*
Operating Speed	min. 5mm/sec (configurable)
Ambient Operating Temp	-5°C to +60°C
Thrust Force	2 x 250N
Close Force	2 x 250N
Soft Close	Yes (via adjustable zero point setting)
Switching	Electronic
Standard Finish	Powder coated Grey (RAL 9006)
Seal Relief	Programmable up to 20mm
Clamping Force	2 x 4000N
Colour Option	Other RAL colours available on request
Flex Length	2m
Flex Type	2 core PVC 4 core (volt free contact)* as option
Flex Colour	Grey
Product Warranty	15,000 cycles
Duty Cycle	22% (approx. 2 mins on, 7 mins off)
Protection Degree	IP20
Bracket	Sill fixing/ face fix/ thru body sill
Synchronisation	Optional
Application	Environmental Ventilation

## DIMENSIONS

DIM X (mm)	DIM Y (mm)	STROKE (mm)
1131	497	Max. 350
1309	675	Max. 350
1359	725	Max. 350

## APPLICATIONS



Environmental Ventilation

## ACCREDITATIONS

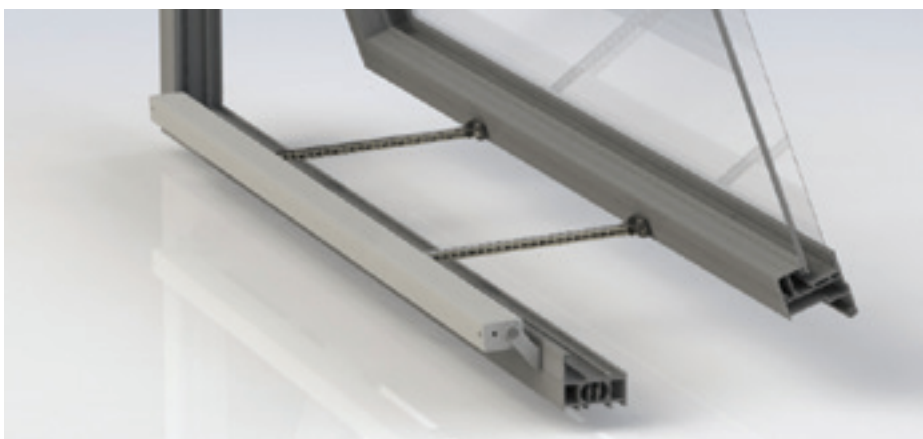

## STANDARD BRACKET DETAIL



## TECHNICAL DRAWING

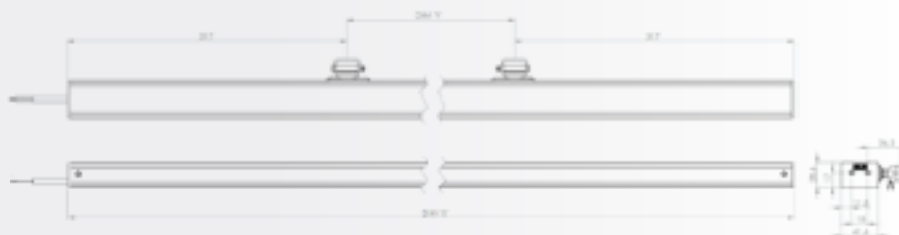

## PRODUCT CODES

SILVER GREY (RAL 9006)	OPERATING VOLTAGE	FORCE	STROKE	ACTUATOR BODY LENGTH	TO SUIT VENT LENGTH
AAST250350S	24V	250N	350mm	1131mm	1150mm
AAST251350S	24V	250N	350mm	1309mm	1350mm
AAST252350S	24V	250N	350mm	1359mm	1450mm

## BRACKET PRODUCT CODES

Height (mm)	Offset (mm)					
	0	5	8	10	15	20
35	AKS18000001	AKS18050001	AKS18080001	AKS18100001	AKS18150001	N/A
40	AKS18000002	AKS18050002	AKS18080002	AKS18100002	AKS18150002	N/A
50	AKS18000003	AKS18050003	AKS18080003	AKS18100003	AKS18150003	AKS18200003

# Brackets

## SERIES 40 BRACKETS - FACE FIX BRACKETS FOR THE SECO Ni 40 ACTUATOR RANGE

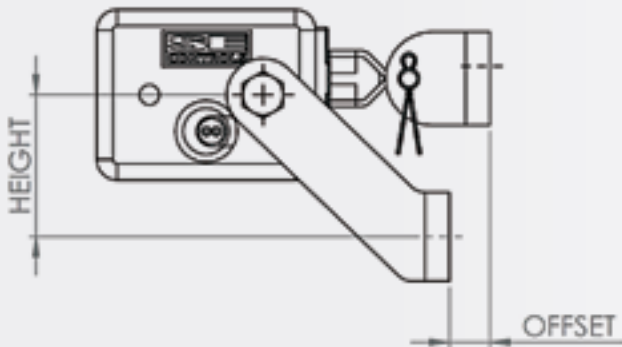

### BRACKET PRODUCT CODES

Height (mm)	Offset (mm)					
	0	5	8	10	15	20
35	AKS16000001	AKS16050001	AKS16080001	AKS16100001	AKS16150001	N/A
40	AKS16000002	AKS16050002	AKS16080002	AKS16100002	AKS16150002	N/A
50	AKS16000003	AKS16050003	AKS16080003	AKS16100003	AKS16150003	AKS16200003

## SERIES 25 BRACKETS - FACE FIX BRACKETS FOR THE SECO N 25 ACTUATOR RANGE

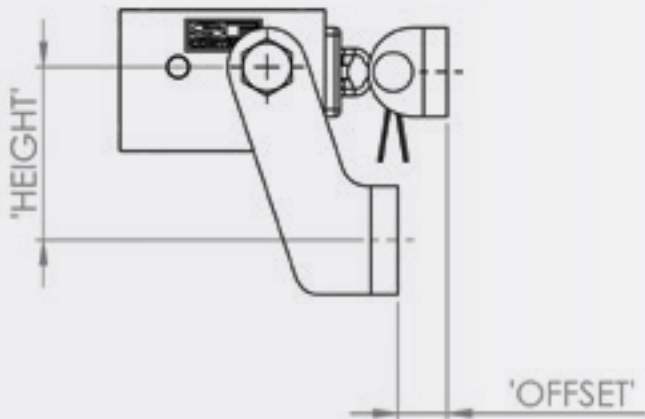

### BRACKET PRODUCT CODES

Height (mm)	Offset (mm)					
	0	5	8	10	15	20
35	AKS18000001	AKS18050001	AKS18080001	AKS18100001	AKS18150001	N/A
40	AKS18000002	AKS18050002	AKS18080002	AKS18100002	AKS18150002	N/A
50	AKS18000003	AKS18050003	AKS18080003	AKS18100003	AKS18150003	AKS18200003

# Open/Close Switches

## SURFACE MOUNTED

- Steel enclosure (80w x 80h x 51d mm) designed to be used with either a key switch or a paddle switch fitting.
- For either switch fitting, a range of switch position options are available:
- 3 positions
- Spring return
- Fixed position
- 2 position spring
- Designed for smoke ventilation applications. Instructional text is etched into the plate's surface for improved durability.

## PRODUCT CODES

Open/Close Key Switch	ATSASSYOC01
Open/Close Smoke Vent Key Switch	ATSASSYSV03
Open/Close Window Control Key Switch	ATSASSYWC03
Open/Close Roof Vent Key Switch	ATSASSYRV03
Open/Close Paddle Switch	ATSASSYOC02
Open/Close Smoke Vent Paddle Switch	ATSASSYSV04
Open/Close Window Control Paddle Switch	ATSASSYWC04
Open/Close Roof Vent Paddle Switch	ATSASSYRV04
Open/Close Rocker Switch	ASM00000003

## FLUSH MOUNTED

- Brushed stainless steel face plate (86w x 86h x 2d mm) designed to be used with either a key switch or a paddle switch fitting.
- For either switch fitting, a range of switch position options are available:
- 3 positions
- Spring return
- Fixed position
- 2 position spring
- Designed for smoke ventilation applications. Instructional text is etched into the plates surface for improved durability.

## PRODUCT CODES

Open/Close Key Switch	ATSASSYOC04
Open/Close Smoke Vent Key Switch	ATSASSYSV01
Open/Close Window Control Key Switch	ATSASSYWC01
Open/Close Roof Vent Key Switch	ATSASSYRV01
Open/Close Paddle Switch	ATSASSYOC05
Open/Close Smoke Vent Paddle Switch	ATSASSYSV02
Open/Close Window Control Paddle Switch	ATSASSYWC02
Open/Close Roof Vent Paddle Switch	ATSASSYRV02
Open/Close Rocker Switch	ASM00000001

## APPLICATIONS



Smoke Ventilation



Environmental Ventilation

## ACCREDITATIONS



## Surface Mounted

### KEY VERSION



### PADDLE VERSION



### ROCKER VERSION



## Flush Mounted

### KEY VERSION



### PADDLE VERSION



### ROCKER VERSION



# SHEVTEC® Smoke Shaft Door Actuator and Door

## DOOR OPENER

Type	Actuator
Usage	Smoke Ventilation
Voltage	24V dc
Current	0.5A
Max Force	2000N
Speed with Nominal Load	Door to open to 90° within 60 seconds
Operating Temperature	In line with EN12101-2:2003 Annex G
Life Cycle	5000
Flex	2 core silicone
Switching	Electronic
Type of Switch	Positional Limiting
Fixing options	Door or frame
IP rating	IP20
Intumescent seal within actuator	Situated around mounting bracket

## FIRE RATED SMOKE DOOR

Type	Door
Usage	Smoke ventilation
Fire Rating	FD30
Intumescent seal around door	Head and Jamb of frame reveal
Smoke/Intumescent seal	Acoustic Smoke Seal & Intumescent Seal comes as standard

## PRODUCT / SOLUTION COMPLIANCE

SHEVTEC® Smoke Shaft Actuator and Door	Principles of EN12101-2: 2003 Annex G - Door to operate after 5 minutes at 300° and open the door to 90° and remain open for 30 minutes
SHEVTEC® Door	BS EN 1363: Part 1: 1999 - Maintain temperature / time relationship during test and not breach the doors integrity within 30 minutes
SHEVTEC® Door	Principles of BS EN 1634:1 - Maintain temperature / time relationship during test and not breach the doors integrity within 30 minutes
Intumescent / Smoke Seals	In accordance to BS 476: part 31: section 31.1
Door frame	BS EN 942:1996 - Specification of material and minimum density

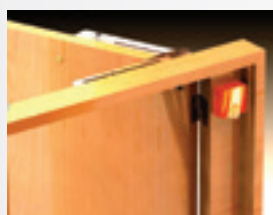

## APPLICATIONS



Smoke Ventilation

## ACCREDITATIONS



Certified & tested in accordance with EN12101-2

# Linear Actuators

WE CAN ALSO SUPPLY A FULL RANGE OF LINEAR ACTUATORS WITH A SELECTION OF STROKE LENGTHS AND PERFORMANCE CAPABILITIES

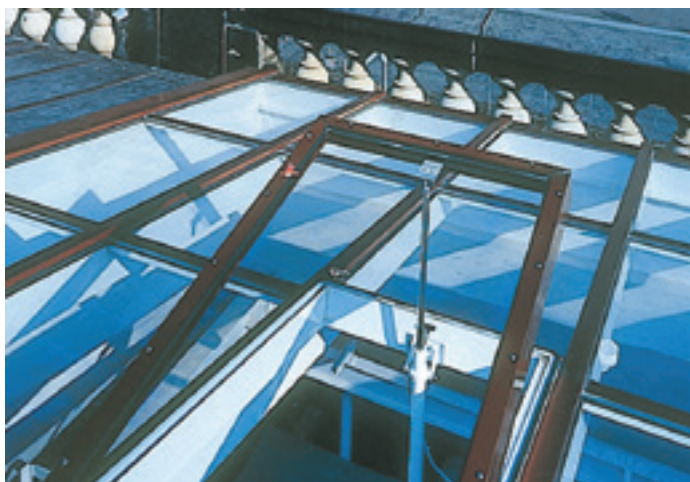
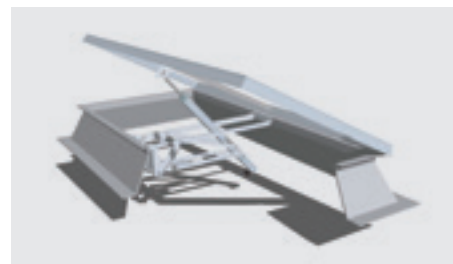

# General Principles of Airflow

The direction of airflow or smoke flow is an important factor when selecting a suitable vent type.

Basic principles of airflow relative to external and internal temperatures and pressures will determine the optimum solution. As well as design guidance and best practice, regulations dictate the hinge arrangements.

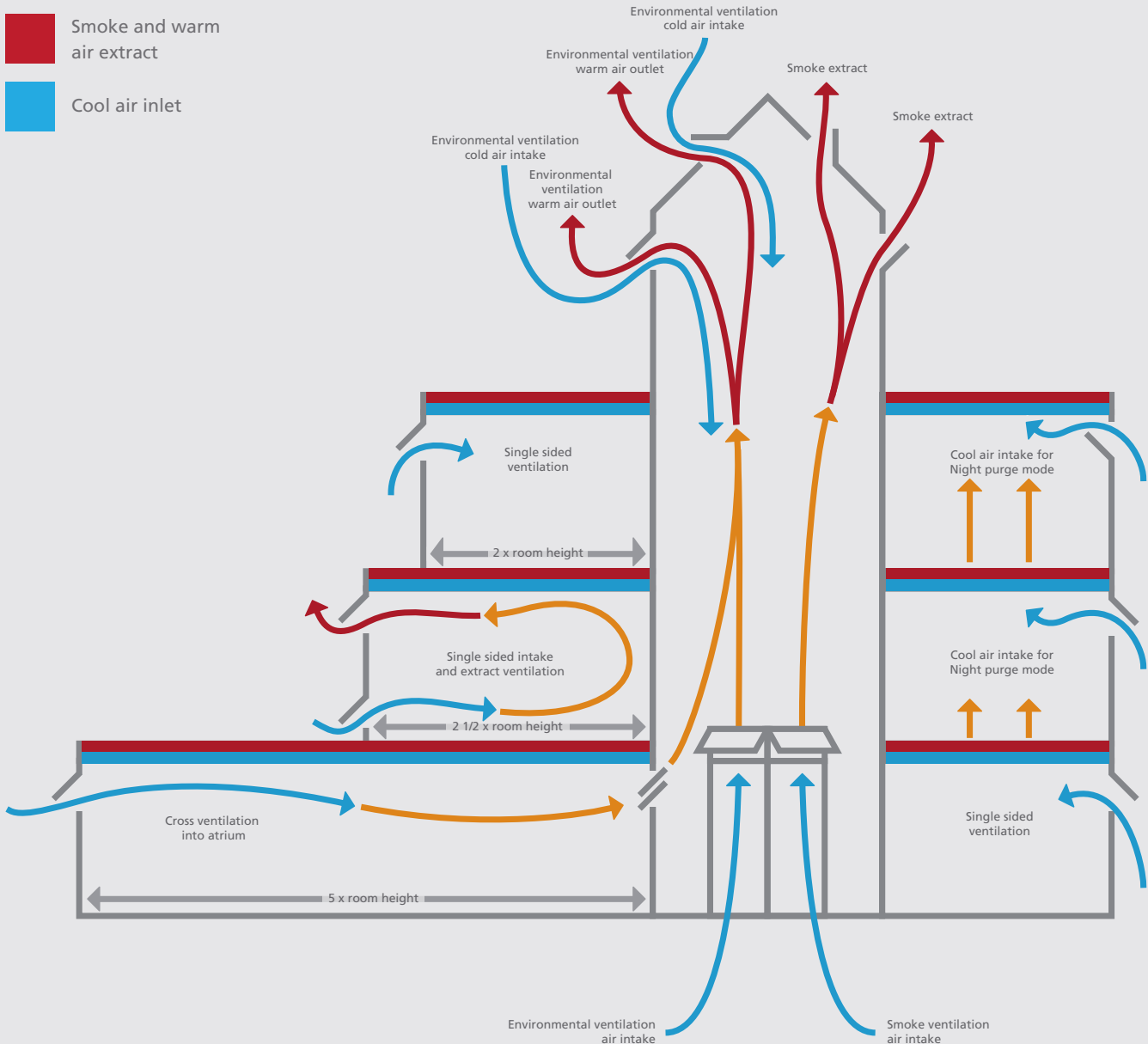

# Regulations and Design Guides

## Construction Products Regulation

The Construction Products Regulation (CPR) lays down harmonised rules for the marketing of construction products in the EU. The regulation provides a common technical language to assess the performance of construction products. It ensures the availability of reliable information in order that the performance of products from different manufacturers in the different countries can be compared.

The CPR represents a continued focus on the safety and other performance aspects of completed construction works and lays down aspects to consider for construction products. The 6 essential requirements of the directive have been extended to become the 7 'basic work requirements' namely: Mechanical resistance and stability; safety in case of fire; hygiene in health and environment; safety and accessibility in use; protection against noise; energy economy including heat retention and a new requirement - sustainable use of natural resources.



## Building Regulations

Building regulations are minimum standards for design, construction and alterations to virtually every building. They are developed by the Government and approved by Parliament.



## Approved Documents

Approved documents provide guidance on ways to meet the building regulations and contain practical examples plus solutions on how to achieve compliance and should be read in conjunction with the regulations to provide clarity.



## Design Guides

Design guides offer additional assistance in achieving regulatory requirements. Often produced by professional trade groups or associations within specialist field.

# Environmental Ventilation



## REGULATIONS AND DESIGN GUIDES:

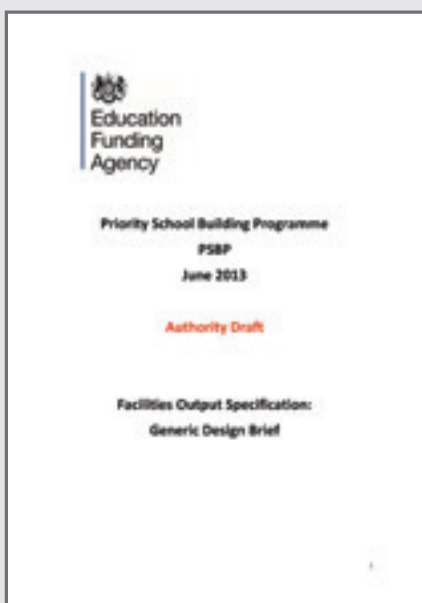
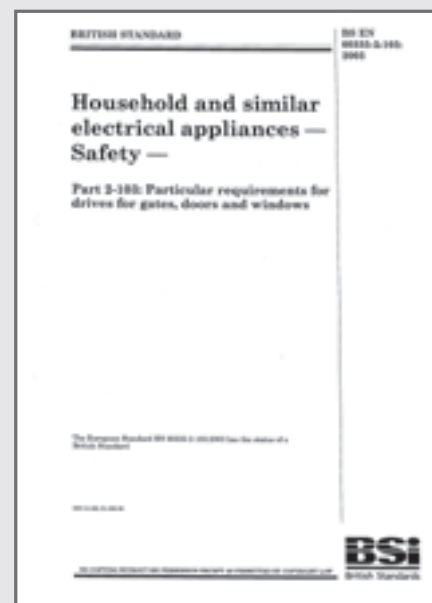
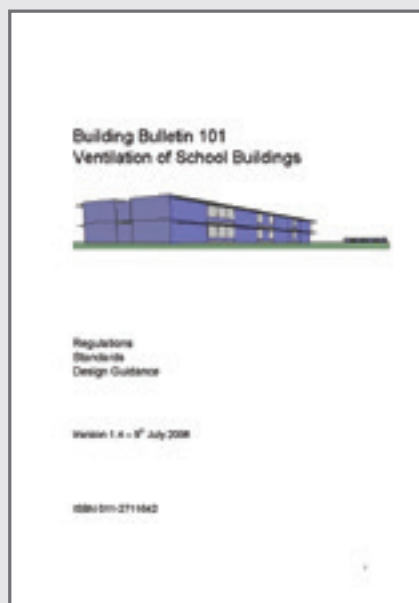

# Smoke Ventilation



## REGULATIONS AND DESIGN GUIDES:



# Security Standards Regulations and Security Schemes

## REGULATIONS AND DESIGN GUIDES:

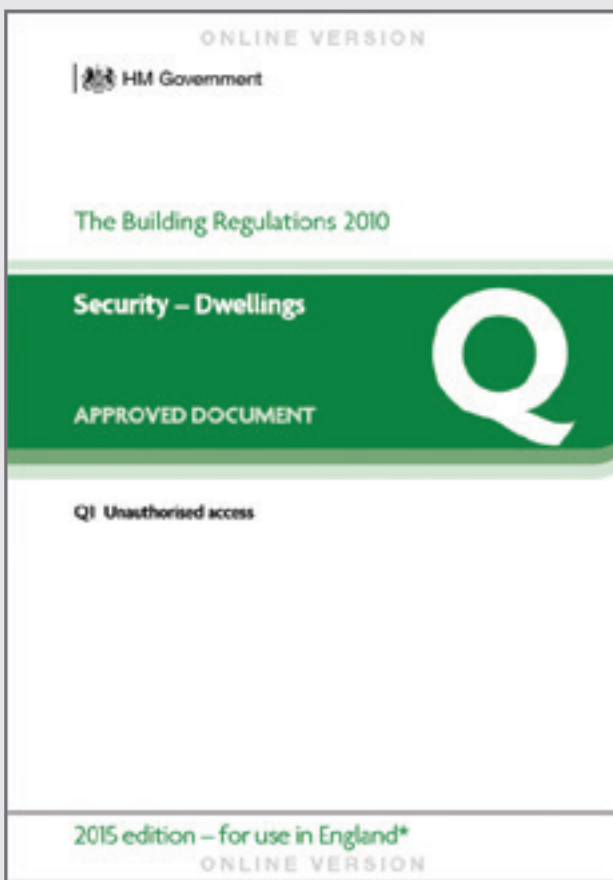

To meet the requirements of both Approved Document Q and SBD the vent must be tested to PAS 24 and be resistant to a force of 3000N. The SECO N actuator has successfully passed this test, providing 4000N per locking point. An audited process is required to certify the vent to PAS 24, whereby the locking point location must be replicated in every different vent width, relative to its position in the test. In accordance with the requirements for SBD within schools, the SECO N range of actuators can also give a signal to advise that a vent is open

# Design Guidance Selection Process

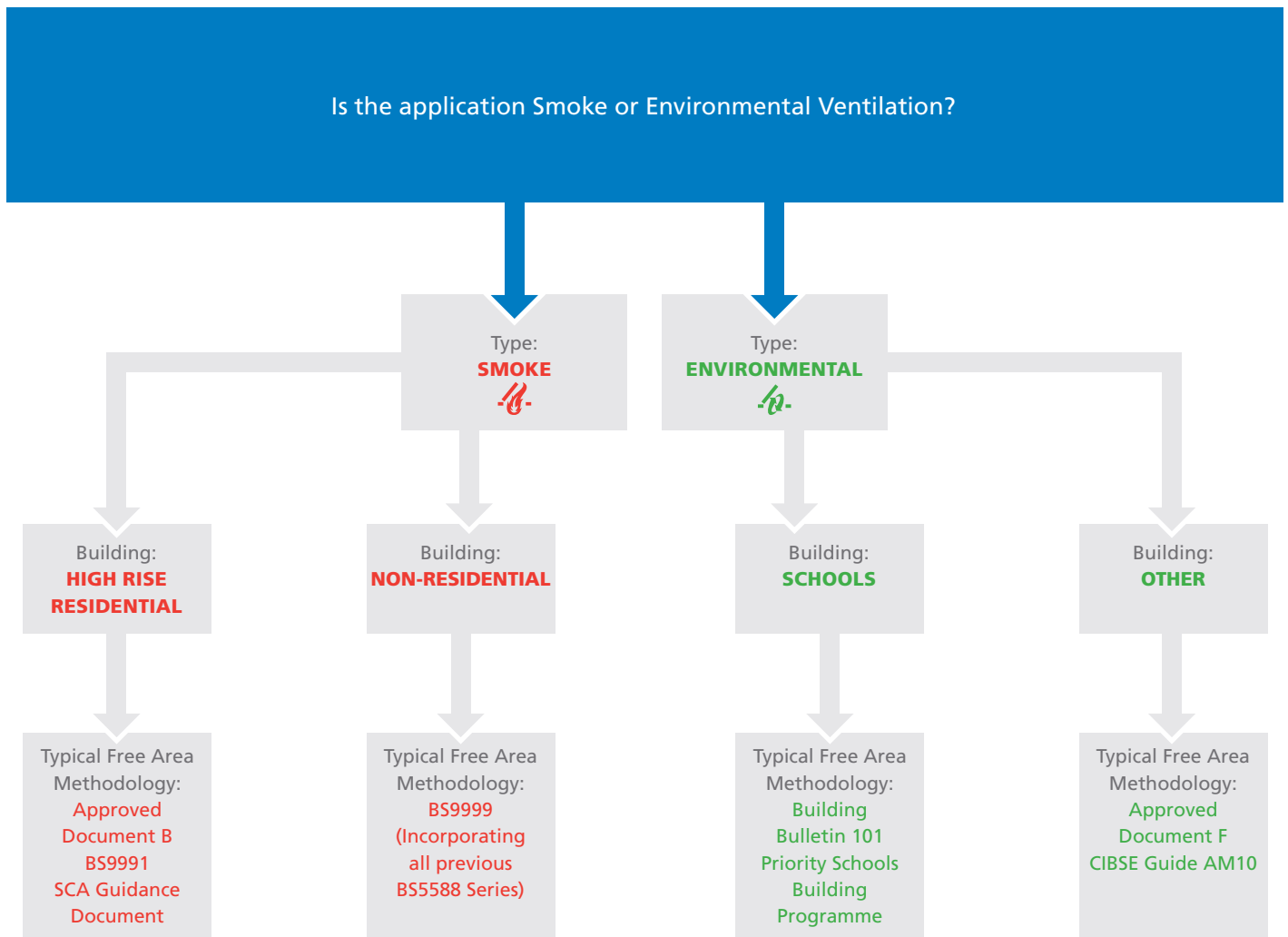

There are generally three methods to measure free area through a vent which are applied relative to the building type and the application (smoke or environmental ventilation).

In all applications, be aware of obstructions such as reveals, recesses, side walls etc., and of course other vents.

# Aerodynamic Free Area Calculation



The internal throat area  $a \times b$  ( $A_v$ ) is multiplied by the efficiency factor or co-efficient of discharge ( $C_v$ ) of the vent which is determined by the opening angle. The opening angle of the vent dictates the efficiency factors achieved, generally 0.3-0.6.

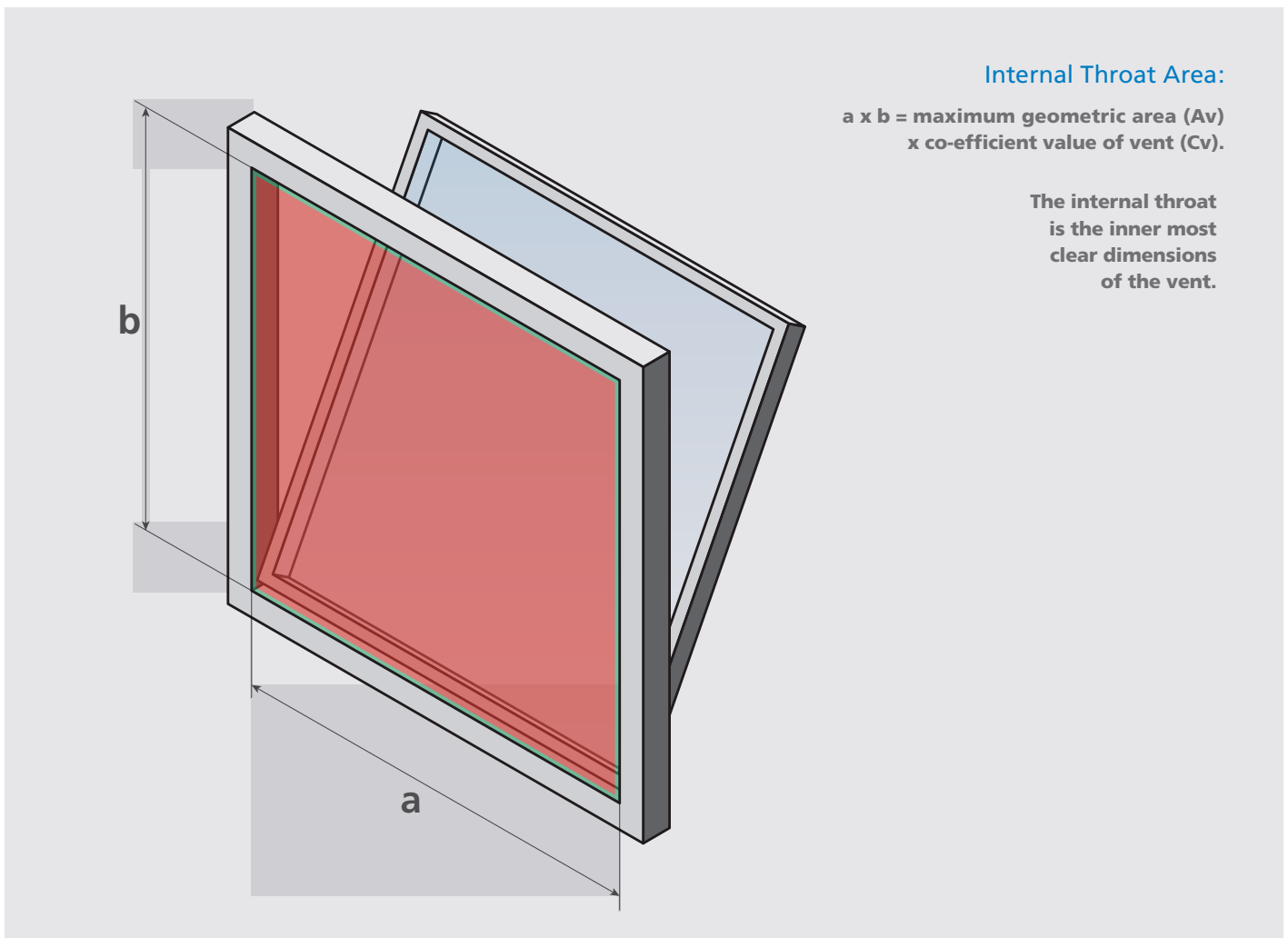

### Typical Example of Aerodynamic Free Area Co-efficient

This information is only available if an aerodynamic test is carried out. Generally 30-60% efficiency factors are achieved dependent upon the opening angle. Assumed Co-efficient values **must not** be used or transferred from one system to another.

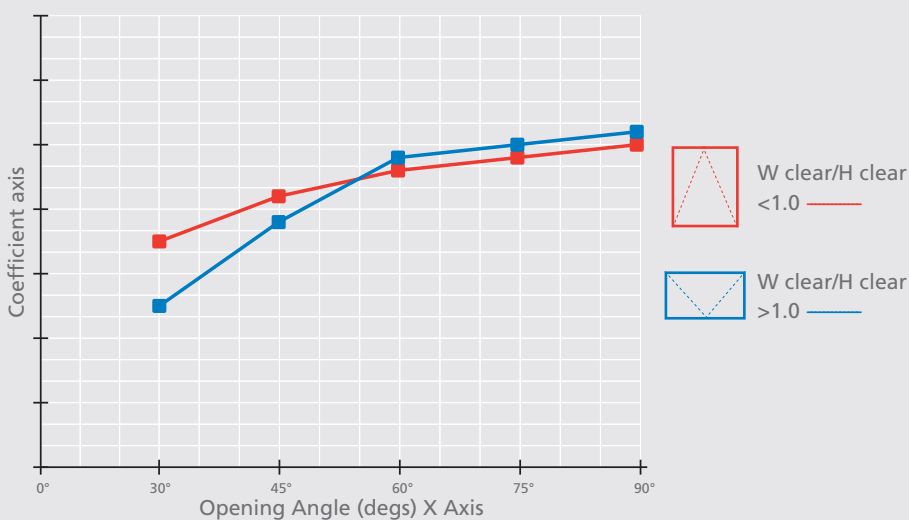

The different results are relative to the aspect ratio of the vent width / height.

### An example of how the aerodynamic calculation works:

Divide the vent width / height to ascertain the correct aspect ratio. Measure the internal throat area of the vent to confirm the maximum geometric free area (Av). Choose the required stroke length for the actuator and establish the opening angle. In accordance with the table, confirm the co-efficient value at that degree of opening. Multiply the maximum geometric area by the coefficient value (Cv) to give the Aerodynamic value (Aa).

$$Aa = Av \times Cv$$

# Geometric Free Area Calculation for High Rise Residential



The measurement of the free area of a vent is defined in Appendix C to Approved Document B (ADB) 2013.

The total unobstructed cross sectional area, measured in plane where the area is at a minimum and at right angles to the direction of air flow (as shown in the diagram below).

Generally 1.0m<sup>2</sup> geometric free area is required for head of stair and 1.5m<sup>2</sup> for end of corridor however each project will have its own design. Aerodynamic free area calculation is also allowed under approved document B.

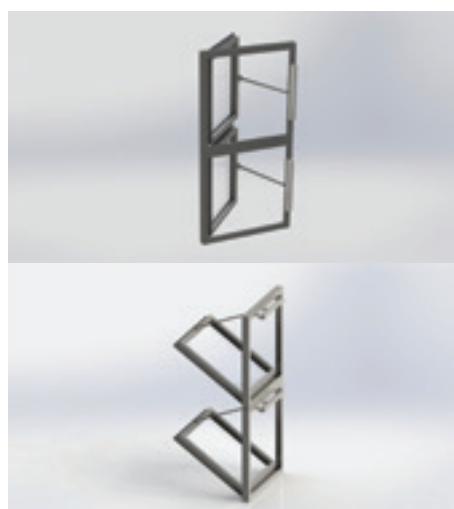
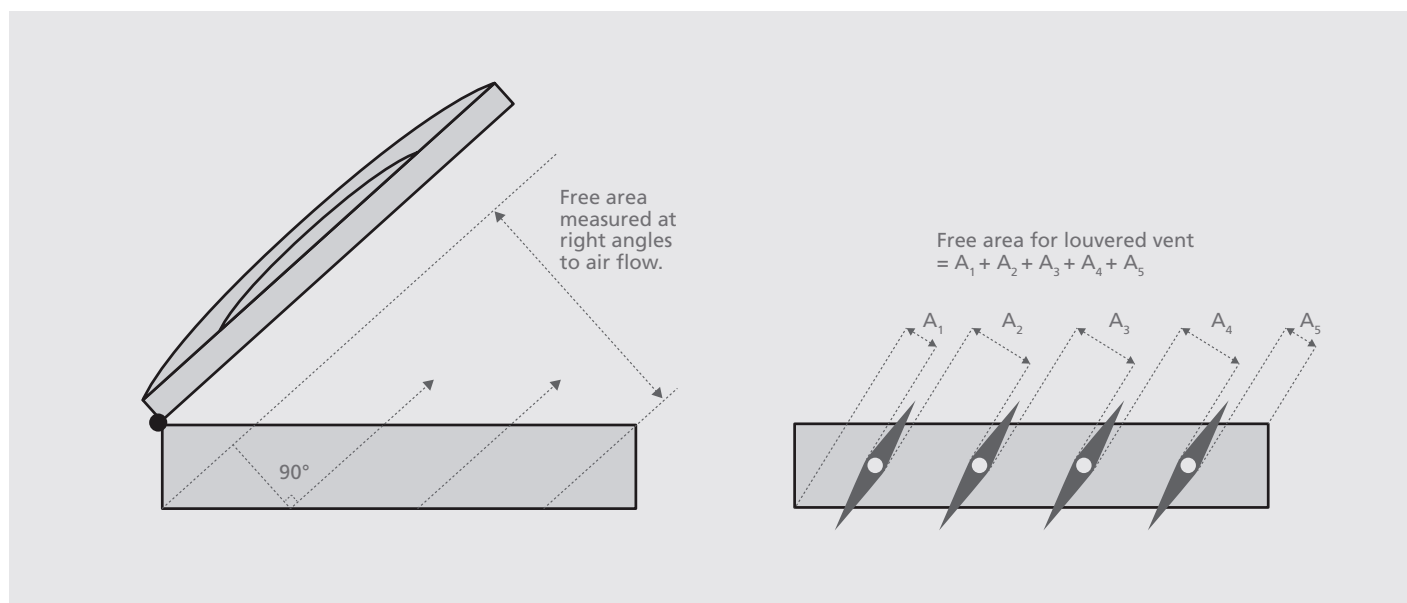

The above images show how Approved Document B describes how you measure free area, but they do not illustrate how this is interpreted for a window. There are documents in existence produced by the Smoke Control Association that seek to give clarity on how this is measured which typically results in a double stacked bottom hung open out or side hung solution, however the ultimate regulation is ADB.

Free area calculations should be submitted for approval to an approved Inspector to be assessed for ADB compliance.

# Effective Area Calculation



Similar to aerodynamic area, this is the effectiveness of the vent rather than physical geometric area.

This method is only used for environmental ventilation applications.  
The physical area produced by opening the window:  $A + 2B \times \text{efficiency factor}$ .  
This area cannot exceed the maximum geometric area of the vent  $a \times b$ .  
Please note that neighbouring vents, obstructions and reveals will impact air flow.

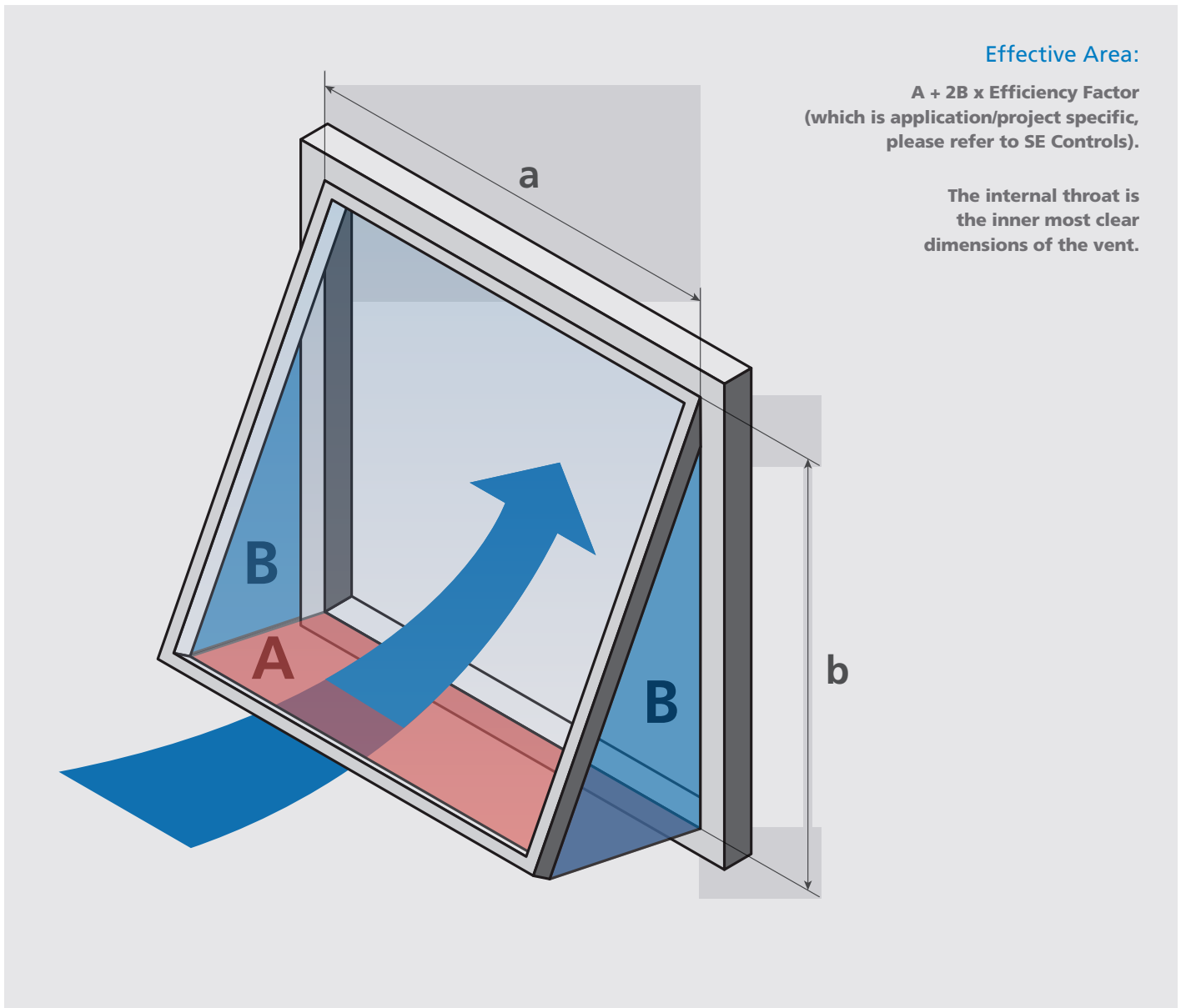

**Effective Area:**

**$A + 2B \times \text{Efficiency Factor}$**   
(which is application/project specific, please refer to SE Controls).

**The internal throat is the inner most clear dimensions of the vent.**

# CPR and CE Marking

Whilst the use of CE marking has been commonly applied to a wide variety of products for a number of years, the need to CE mark products sold into the UK Construction market became mandatory in July 2013 when the Construction Product Directive became the Construction Products Regulation (CPR).

The CPR mandates that where a European harmonised standard exists for a product, a manufacturer must draw up a declaration of performance and apply CE marking to this product. Any product that has a harmonised European standard that is placed upon the construction market must be CE marked against that standard.

The risks of non compliance are refusal of payment, LAD's due to delays in handover and criminal prosecution for failing to meet mandatory life safety standards.

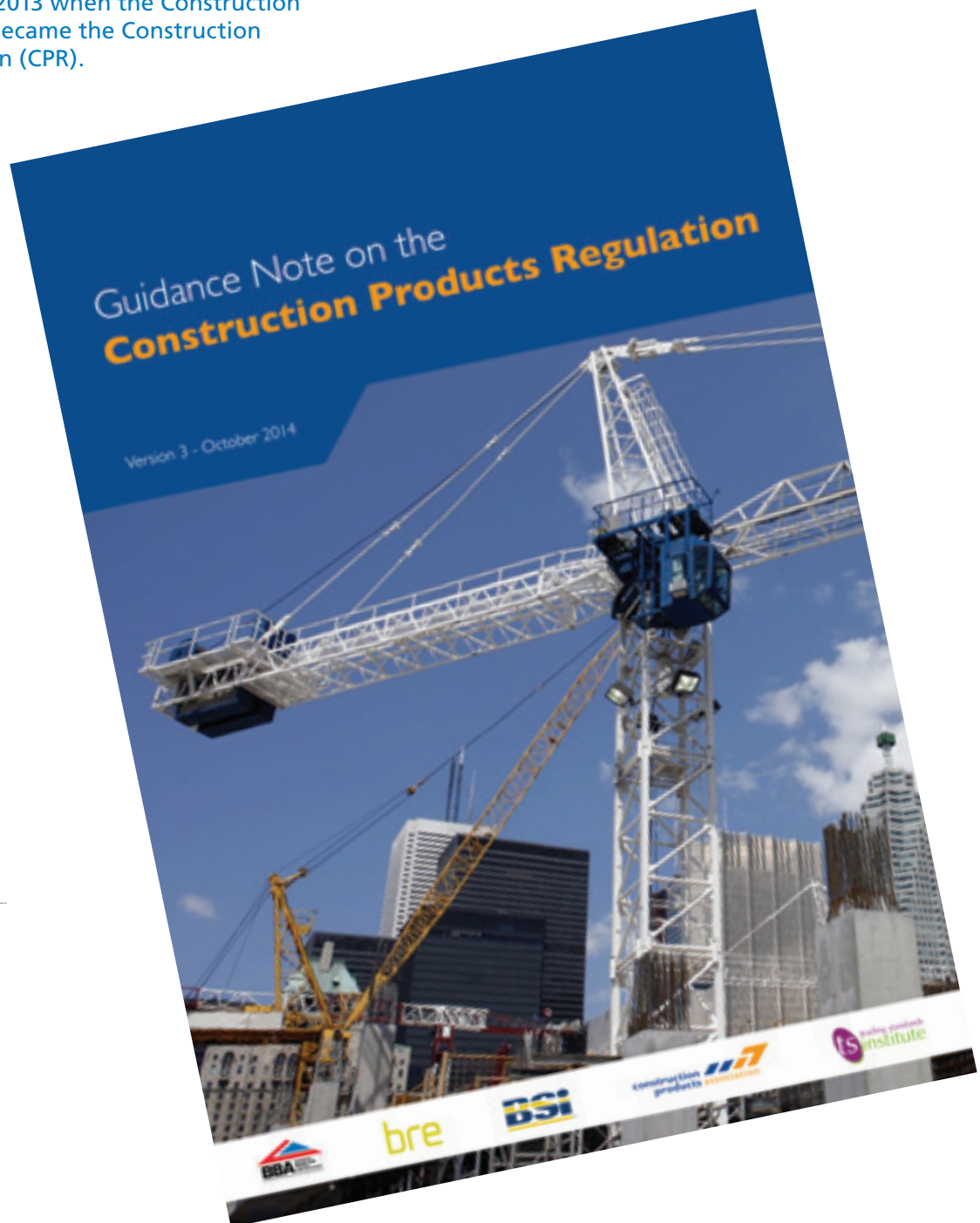
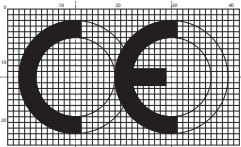

# CE Marking Process Under CPR

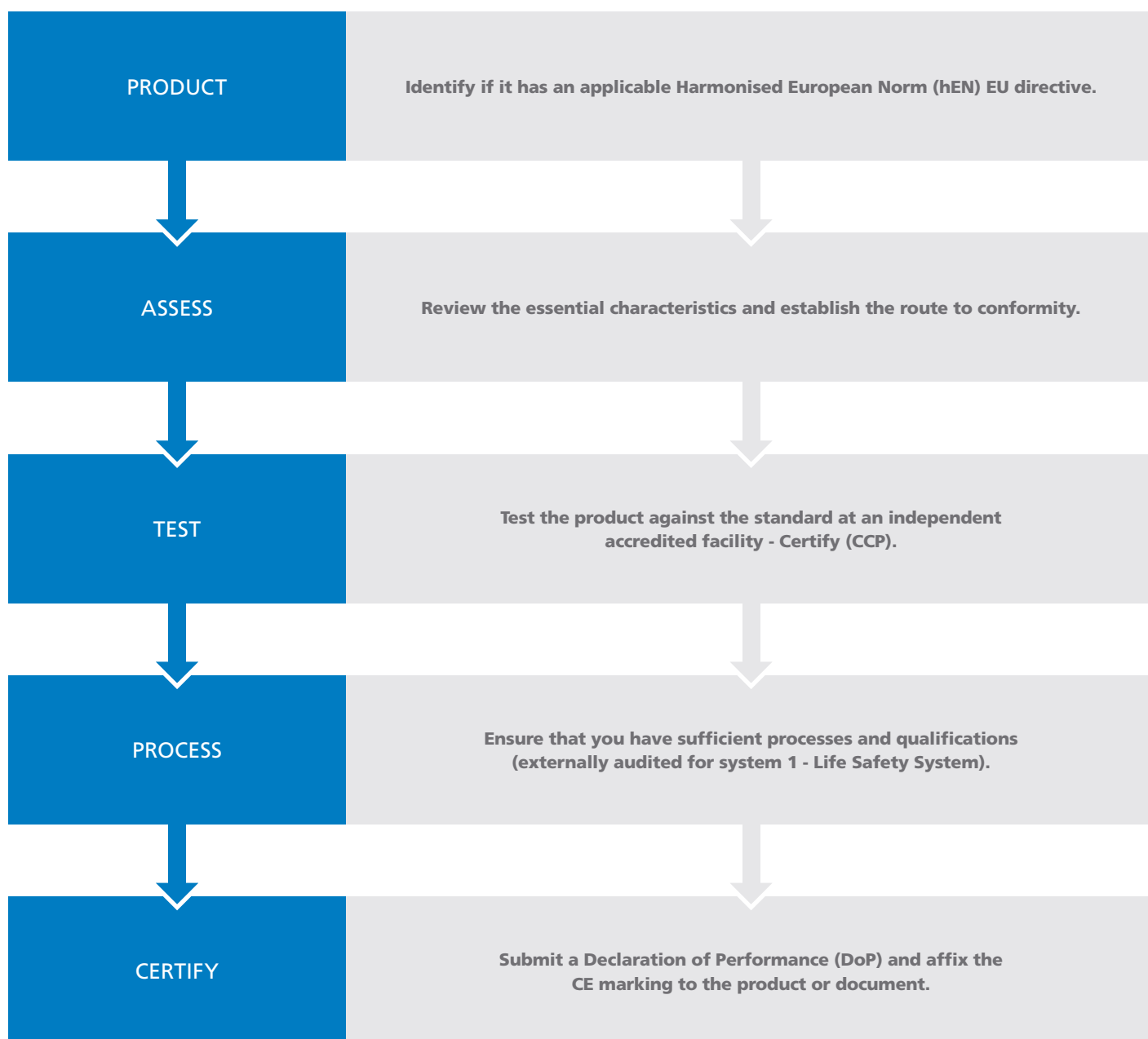

# Introduction to EN 12101

## THE EN 12101 PRODUCT STANDARD FAMILY

<b>PART 1</b>	Specification for smoke barriers	<b>PART 6</b>	Specification for pressure differential systems
<b>PART 2</b>	<b>Natural Smoke And Heat Exhaust Ventilators (SHEVs)</b>	<b>PART 7</b>	Smoke control sections
<b>PART 3</b>	Specification for powered SHEVs	<b>PART 8</b>	Smoke control dampers
<b>PART 4</b>	Installed SHEVs systems for smoke and heat ventilation	<b>PART 9</b>	<b>Control panels (pr EN)</b>
<b>PART 5</b>	Guidelines on functional recommendations and calculation methods for SHEVs	<b>PART 10</b>	<b>Power supplies</b>

# EN 12101 Part 2

EN 12101-2 dictates that an opening smoke vent is in itself a unique product which can only be CE marked if it meets certain criteria. The vent profile and actuator need to be tested together to comply to EN 12101-2 at an accredited testing facility.

The installation onsite must be identical to the test. Therefore an audited certified Factory Production Control (FPC) process must be followed, with accompanying documentation.

As this is a life safety product, the CPR does not allow alternative products to be utilised, other than the prescriptive products used in the test.

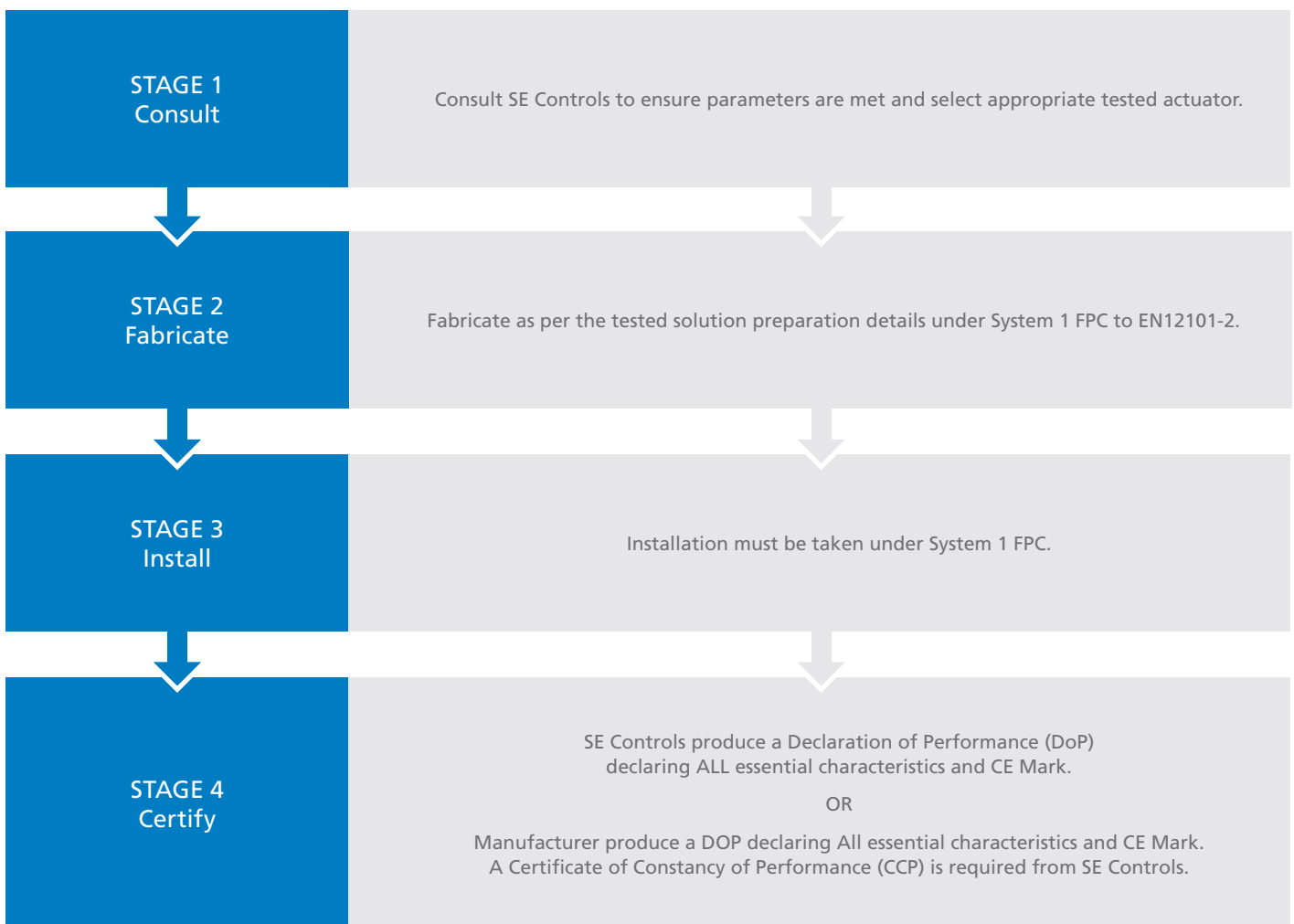

Note: The CE Mark does not solely satisfy the requirements of the CPR, it is only a part of it. The ultimate document to prove compliance is the DoP which is signed by a director of the company placing the product onto the market. The DoP must contain references to the tests, notified body and declare performance against all essential characteristics required by the standard.

# Harmonised Standards for Controls

Certified life safety smoke vents must be operated by suitably certified controls systems. SE Controls manufacture, install, commission and maintain such systems.

## prEN 12101-9

This part of EN 12101 specifies the product performance requirements, classifications and test methods for control systems designed for use in smoke and heat control systems in buildings.



## EN 12101-10

This part of EN 12101 specifies requirements and gives test methods for primary and secondary electrical and pneumatic power supply equipment, designed for use in smoke and heat control systems in buildings.

The standard requires that the product is tested **as a whole**. Certification of individual components does not substantiate compliance.



BS 7346-8 states the compliance requirements for all smoke ventilation components. In addition to the smoke vent itself (part 2) there are 2 European norms for the controls that operate the vents Parts 9 and 10.

# SE Controls BIM Accreditation

Building Information Modelling (BIM) is the generation and management of digital representations, or BIM Objects, of physical and functional characteristics of places to ensure data of the built environment is carried from design, through construction to the maintenance and operation of the building.

The Government Construction Strategy, published in 2011, announced the Government's intention to require electronic collaborative 3D BIM on centrally procured public sector projects by April 2016. Please contact SE Controls for details of available BIM Objects.

The key elements are:

<b>PART 1</b>	<b>Employer's Information Requirement</b>	<b>PART 4</b>	<b>Common classification of data</b>
<b>PART 2</b>	<b>Collaborative working</b>	<b>PART 5</b>	<b>Information exchange methods</b>
<b>PART 3</b>	<b>Individually authored models</b>	<b>PART 6</b>	<b>Creation of a federated model</b>

# Contact us

## HEAD OFFICE:

### SE CONTROLS - UNITED KINGDOM (LICHFIELD)

Lancaster House, Wellington Crescent, Fradley Park, Lichfield, Staffs, UK, WS13 8RZ

**Tel:** +44 (0) 1543 44 30 60

**Fax:** +44 (0) 1543 44 30 70

**Email:** info@secontrols.com

### SE CONTROLS - ASIA PACIFIC (HONG KONG)

Unit 301, 3/F Hung To Centre,  
94-96 How Ming Street, Kwun  
Tong, Kowloon, Hong Kong

香港九龍觀塘巧明街94-96號，鴻圖中心3樓1

**Tel:** 00 852 811 18213

**Email:** secap@secontrols.com

### SE CONTROLS - AFRICA (DURBAN)

96 Marine Drive, Bluff, Durban,  
KZN, South Africa, 4052

**Tel:** +27 (0) 31 4661857

**Email:** secaf@secontrols.com

### SE CONTROLS - MIDDLE EAST FZE

Office 504, Academy Zone01-  
Business Center 5, Business Park,  
Ras Al Khaimah Free Trade Zone.  
PO BOX 16496, UAE

**Tel:** 009 7172 075544

**Fax:** 009 7172 075566

**Mob:** +97 152 844 6705

**Email:** secme@secontrols.com

### SE CONTROLS - INDIA (CHENNAI)

120, Ground Floor, Defence Colony, Second  
Avenue, Chennai - 600032, Tamil Nadu

**Tel:** +91 44 42121 694

**Mob:** +91 99406 64360

**Email:** secin@secontrols.com

**GET IN TOUCH WITH A MEMBER  
OF OUR TEAM FOR ADVICE OR  
ASSISTANCE ON DESIGN, SUPPLY,  
INSTALLATION OR MAINTENANCE....**

 +27 (0) 31 466 1857

 secaf.admin@secontrols.com

 www.secontrols.co.za

## ACCREDITATIONS



Accredited Contractor



IFC



CPD CERTIFIED



CAB



SMOKE CONTROL ASSOCIATION



CIBSE



MADE IN BRITAIN



HEVAC

## JOIN OUR LINKEDIN GROUP:



## SEARCH FOR US ON:





REGISTER FOR AN AUTOMATIC UPDATE TO THIS LITERATURE BY  
SENDING AN EMAIL TO [BROCHURES@SECONTROLS.COM](mailto:BROCHURES@SECONTROLS.COM)

VISIT [WWW.SECONTROLS.CO.ZA/LIBRARY](http://WWW.SECONTROLS.CO.ZA/LIBRARY) FOR ACCESS TO ALL OF OUR LITERATURE.



SE Controls



96 Marine Drive, Bluff, Durban, South Africa, 4052



+27 (0) 31 466 1857 DBN



+27 (0) 82 451 7001 JHB



+27 (0) 82 496 0863 CPT



secaf.admin@secontrols.com



www.secontrols.co.za



SE Controls is a registered trademark

*Creating a Healthier and Safer Environment*