

OMAL

ATTUATORI E VALVOLE AUTOMATICHE ACTUATOR AND AUTOMATED VALVES

Attuatori pneumatici, Attuatori elettrici, Valvole a sfera manuali e automatizzate, Valvole a farfalla manuali e automatizzate, Valvole pneumatiche assiali, Valvole a flusso avviato
pneumatic actuators, electric actuators, manual or actuated ball valves, manual or actuator actuated butterfly valves, co axial pneumatic valves, angle seat valves

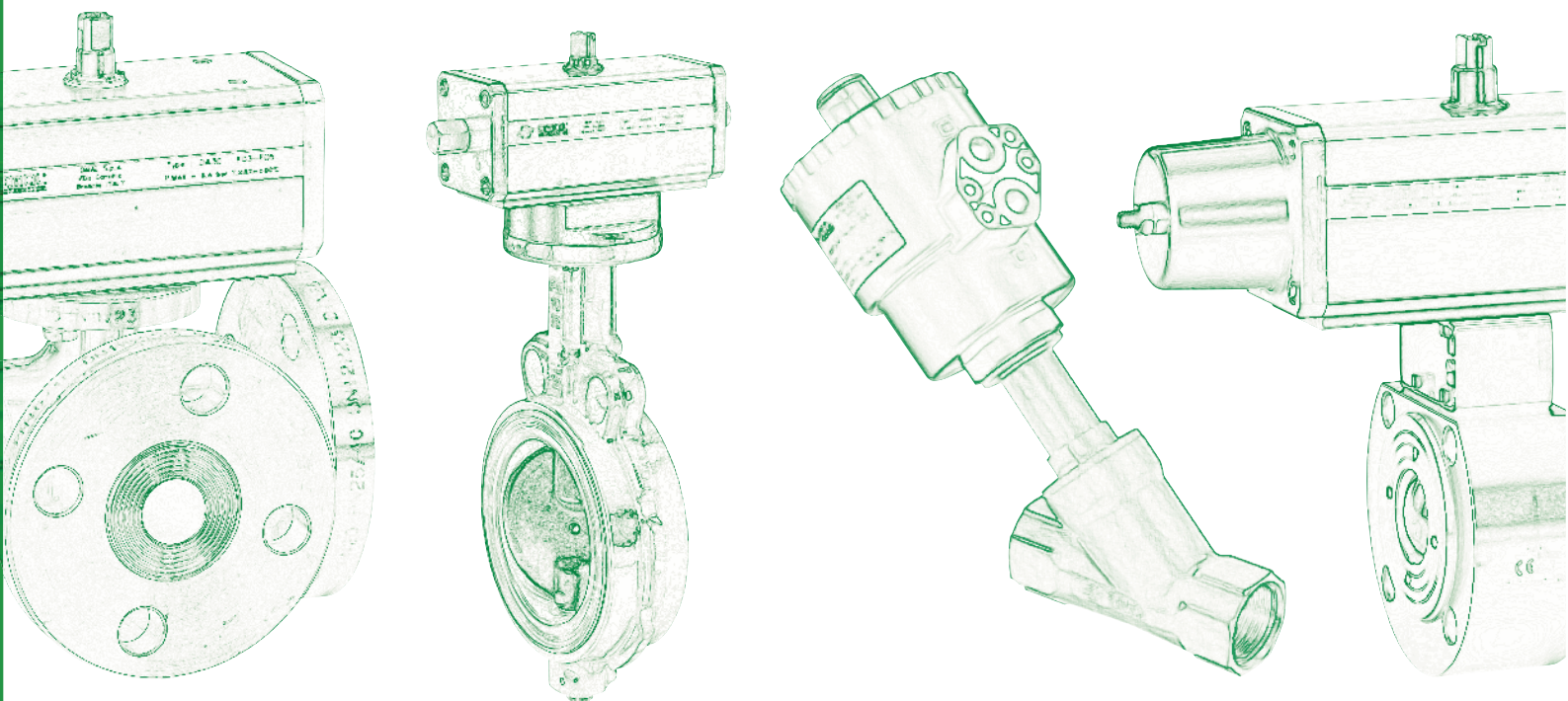

OMAL®
AUTOMATION



ATTUATORI ACTUATORS ANTRIEBE ACTIONNEURS



ATTUATORI PNEUMATICI PNEUMATIC ACTUATORS PNEUMATISCHE ANTRIEBE ACTIONNEURS PNEUMATIQUES

Attuatori pneumatici in alluminio anodizzato doppio e semplice effetto
Disponibili in versione: Nichelata; Verniciata epossidicamente;
in AISI 316 e con dispositivo di dosaggio.

Spring Return and Double Acting pneumatic actuators in anodized
aluminum. Available versions: nickel plated, epoxy varnished, AISI
316 and available.

*Doppelt bzw einfachwirkende Drehantriebe. Standard Alu eloxiert.
Nach Wunsch mit chemischer Vernickelung, epoxidischer Lackie-
rung oder in AISI 316. Pneumatischer Dosierantrieb nach Anfrage.*



ATTUATORI ELETTRICI ELECRCIC ACTUATORS ELEKTRISCHE ANTRIEBE ACTIONNEURS ELECTRIQUES

MOD. EA da 35 Nm a 240 Nm MOD. AE da 10 Nm a 2000 Nm
Disponibili in versione modulante o ON-OFF
Tensioni: 24 Vac; 24 Vac/dc; 24 Vdc; 115 Vac 50/60 Hz; 230 Vac 50/60 Hz.

MOD. EA from 35 Nm to 240 Nm, MOD. AE from 10 Nm to 2000 Nm
Available in modulating or ON-OFF versions Voltage: 24V ac; 24V
ac/dc; 24V dc; 115V ac 50/60 Hz; 230V ac 50/60 Hz.

MOD. EA von 35 Nm bis 240 Nm MOD. AE von 10 Nm bis 2000 Nm 2
Baureihen: auf/zu und Kontinuirlich regelbarer Antrieb
Spannung: 24 Vac; 24 Vac/dc; 24 Vdc; 115 Vac 50/60 Hz; 230 Vac 50/60
Hz.



VALVOLE AUTOMATIZZATE



ART. D-S 100-101 OTTONE/BRASS/MESSING/LAITON

Valvola a sfera 2 vie filettata con attacco ISO dal 3/8" al 2"	2-way threaded ball valve with ISO flange from 3/8" to 2"
<i>Robinet à boisseau sphérique 2 voies taraudé avec ISO attachment de 3/8" à 2"</i>	2-Wege Kugelhahn, Innengewinde, mit ISO Flansche ab 3/8" bis 2"



ART. D-S 115 OTTONE/BRASS/MESSING/LAITON

Valvola a sfera 2 vie flangiata corpo piatto dal DN 15 al DN 50	2-way flat body flanged ball valve from DN 15 to DN 50
<i>Robinet à boisseau sphérique 2 voies avec brides de longueur réduite de DN 15 à DN 50</i>	2-Wege Kompakt Flansch-Kugelhahn ab DN 15 bis DN 50



ART. D-S 153/160/161 OTTONE/BRASS/MESSING/LAITON

Valvola a sfera 3 vie filettata "T" o "L" dal 1/2" al 2"	3-way "T" or "L" port threaded ball valve from 1/2" to 2"
<i>Robinet à boisseau sphérique 3 voies taraudé en "T" ou "L" de 1/2" à 2"</i>	3-Wege Kugelhahn "T" oder "L" Bohrung, Innengewinde ab 1/2" bis 2"



ART. D-S 400/401 ACCIAIO INOX/STAINLESS STEEL/EDELSTAHL/ACIER INOX

Valvola a sfera 2 vie filettata dal 3/8" al 4"	2-way threaded ball valve from 3/8" to 4"
<i>Robinet à boisseau sphérique 2 voies taraudé de 3/8" à 4"</i>	2-Wege Kugelhahn, Innengewinde, ab 1/2" bis 4"



ART. D-S 406 ACCIAIO INOX/STAINLESS STEEL/EDELSTAHL/ACIER INOX

Valvola a sfera 2 vie flangiata dal DN 10 al DN 100	2-way flanged ball valve from DN 10 to DN 100
<i>Robinet à boisseau sphérique 2 voies avec brides de DN 10 à DN 100</i>	2-Wege Flansch-Kugelhahn ab DN 10 bis DN 100



ART. D-S 412 ACCIAIO INOX/STAINLESS STEEL/EDELSTAHL/ACIER INOX

Valvola a sfera 2 vie flangiata "split wafer" dal DN 50 al DN 200	2-way flanged ball valve "split wafer" from DN 50 to DN 200
<i>Robinet à boisseau sphérique 2 voies avec brides "split wafer" de DN 50 à DN 200</i>	2-Wege Flansch-Kugelhahn "split wafer" ab DN 50 bis DN 200



AUTOMATED VALVES



ART. D-S 415
ACCIAIO INOX/STAINLESS STEEL/EDELSTAHL/ACIER INOX

Valvola a sfera 2 vie flangiata corpo piatto dal DN 15 al DN 100 2-way flat body flanged ball valve from DN 15 to DN 100

Robinet à boisseau sphérique 2 voies avec brides delongueur de DN 15 à DN 100 **2-Wege Kompakt Flansch-Kugelhahn ab DN 15 bis DN 100**



ART. D-S 424
ACCIAIO INOX/STAINLESS STEEL/EDELSTAHL/ACIER INOX

Valvola a sfera 2 vie in 3 pezzi filettata e da saldare dal 3/8" al 2" 2-way 3-piece threaded or butt weld ball valve from 3/8" to 2"

Robinet à boisseau sphérique 2 voies taraudé ou soudé avec tirants de 3/8" à 2" **2-Wege Kugelhahn, dreiteilig, Innengewinde oder Schweissenden, ab 3/8" bis 2"**



ART. D-S 434
ACCIAIO INOX/STAINLESS STEEL/EDELSTAHL/ACIER INOX

Valvola a sfera 2 vie filettata femmina DIN 11851 dal DN 10 al DN 100 2-way ball valve DIN 11851 threads from DN 10 to DN 100

Robinet à boisseau sphérique taraudé DIN 11851 de DN 10 à DN 100 **2-Wege Kugelhahn nach DIN 11851 ad DN 10 bis DN 100**



ART. D-S 448/450/451/464/465
ACCIAIO INOX/STAINLESS STEEL/EDELSTAHL/ACIER INOX

Valvola a sfera 3 vie filettata "L", "T" o deviatore dal 3/8" al 4" 3-way L/T port threaded ball valve from 3/8" to 4"

Robinet à boisseau sphérique 3 voies taraudé en "L" ou "T" de 3/8" à 4" **3-Wege Kugelhahn L/T bohrung, Innengewinde, ab 3/8" bis 4"**



ART. D-S 460/461
ACCIAIO INOX/STAINLESS STEEL/EDELSTAHL/ACIER INOX

Valvola a sfera 3 vie filettata "L", "T" flangiata dal DN 10 al DN 100 3-way L/T port flanged ball valve from DN 10 to DN 100

Robinet à boisseau sphérique 3 avec brides en "L" ou "T" de DN 10 à DN 100 **3-Wege flansch-kugelhahn, L/T Bohrung ab DN 10 bis DN 100**



ART. D-S 490/492/493
ACCIAIO INOX/STAINLESS STEEL/EDELSTAHL/ACIER INOX

Valvola a farfalla filettata gas, DIN o da saldare dal 1" al 4" GAS, DIN threaded or butt weld butterfly valve from 1" to 4"

Vanne a papillon taraudée GAS, DIN ou de souder de 1" à 4" **Absperrklappe mit GAS, DIN Gewinde oder Schweissenden ab 1" bis 4"**



AUTOMATISIERTE ARMATUREN

Completano la gamma versioni speciali e applicazioni personalizzate che permettono a OMAL di soddisfare ogni esigenza di automazione nelle più differenti condizioni di utilizzo. A wide range of special units are available on request, please contact OMAL for further information. Wir abeneine umfangreiche Reihe von Sonderausführungen verfügbar, bitte setzen Sie sich für weitere Infomationen mit OMAL in Verbindung. La gamme st complètée par des versions spéciales et des applications personnalisées permettant à OMAL de satisfaire toute exigence d'automatation dans les conditions d'exercice les plus variées.

ART. D-S 512

ACCIAIO AL CARBONIO/CARBON STEEL /KOHLENSTHAL/ACIER AU CARBONE

Valvola a sfera 2 vie flangiata "split wafer" dal DN 50 al DN 200 2-way flanged ball valve "split wafer" from DN 50 to DN 200

Robinet à boisseau sphérique 2 voies avec brides "split wafer" de DN 50 à DN 200 **2-Wege Flansch-Kugelhahn "split wafer" ab DN 50 bis DN 200**

ART. D-S 515

ACCIAIO AL CARBONIO/CARBON STEEL /KOHLENSTHAL/ACIER AU CARBONE

Valvola a sfera 2 vie flangiata corpo piatto dal DN 15 al DN 100 2-way flat body flanged ball valve from DN 15 to DN 100

Robinet à boisseau sphérique 2 voies avec brides de longueur reduite de DN 15 à DN 100 **2-Wege Kompakt Flansch-Kugelhahn ab DN 15 bis DN 100**

ART. D-S 526

ACCIAIO AL CARBONIO/CARBON STEEL /KOHLENSTHAL/ACIER AU CARBONE

Valvola a sfera 2 vie filettata alta pressione dal 3/8" al 2" 2-way high pressure threaded ball valve from 3/8" to 2"

Robinet à boisseau sphérique pour haute pression 2 voies taraudé de 3/8" à 2" **2-Wege Hochdruck-Kugelhahn, Innengewinde, ab 3/8" bis 2"**

ART. D-S 612-614 P.V.C.

Valvola a 2 vie filettata o da incollare dal 3/8" al 2" 2-way threaded or bonded ball valve from 3/8" to 2"

Robinet à boisseau sphérique 2 voies taraudé de 3/8" à 2" **2-Wege Kugelhahn Gewinde- oder Klebemuffen ab 3/8" bis 2"**

ART. D-S 645-646-647-648 P.V.C.

Valvola a 3 vie "T" o "L" filettata o da incollare dal 1/2" al 2" 3-way "T" or "L" port threaded or bonded ball valve from 1/2" to 2"

Robinet à boisseau sphérique 3 voies taraudé en "T" ou "L" de 1/2" à 2" **3-Wege Kugelhahn "T" oder "L" Gewinde- oder Klebemuffen ab 1/2" bis 2"**

ART. D-S 270-375-376-377

Valvola a farfalla "WAFER" disponibile in diversi materiali dal DN 40 al DN 600 "WAFER" butterfly valves in different materials from DN 40 to DN 600

Vannes a papillon "WAFER" disponible dans different matériaux de DN 40 à DN 600 **"WAFER" Absperrklappen in verschiedenen Materialien ab DN 40 bis DN 600**

ART. D-S 385-386-387

Valvola a farfalla "LUG" disponibile in diversi materiali dal DN 40 al DN 600 "LUG" butterfly valves in different materials from DN 40 to DN 600

Vannes a papillon "LUG" disponible dans different matériaux de DN 40 à DN 600 **"LUG" Absperrklappen in verschiedenen Materialien ab DN 40 bis DN 600**





ACCESSORI ACCESSORIES ZUBEHÖRE ACCESSORIES



Elettrovalvole ISO

ISO solenoid valves

ISO Magnetventile

Electrodistributeurs ISO

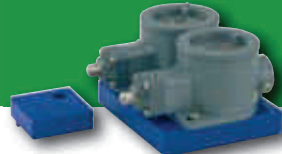

Finecorsa antideflagranti EExd IIC T6

Explosion proof limit switches EExd IIC T6

Ex-geschützte Endschalter EExd IIC T6

Fin de course antidéflagrant EExd IIC T6



Elettrovalvole NAMUR

NAMUR solenoid valves

NAMUR Magnetventile

Electrodistributeurs NAMUR



Box di segnalazione con finecorsa

Limit switch box

Endschalterbaukasten

Boite avec int. fin de course



Elettrovalvola 3/2 per attuatore semplice effetto

3/2 way solenoid valve for "SR" actuators

3/2 wege Magnetventile für "SR" Antrieb

Electrodistributeurs 3/2 pour actionneur "SR"



Box di segnalazione con finecorsa

Limit switch box

Endschalterbaukasten

Boite avec int. fin de course



Finecorsa induttivi

Proximity limit switches

Annäherungsendschalter

Fin de course proximite



Posizionatore pneumatico

Pneumatic positioner

Pneumatischer Stellungsregler

Positionneur pneumatique

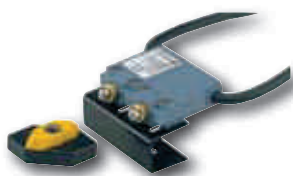

Finecorsa meccanici IP67

Mechanic limit-switches IP67

Mechanische Endschalter IP67

Fin de course mechaniques IP67



Posizionatore elettropneumatico

Electropneumatic positioner

Electropneumatischer Stellungsregler

Positionneur electropneumatique



Finecorsa pneumatici

Pneumatic limit-switches

Pneumatische Endschalter

Fin de course pneumatiques



Operatore manuale di sblocco

Manual override with hand wheel

Schneckengetriebe

Redecteur de secours



VALVOLE PNEUMATICHE PNEUMATIC VALVES VANNES PNEUMATIQUES PNEUMATISCHE SPERRVENTILE



VALVOLE A FLUSSO AVVIATO ANGLE SEAT-VALVE SCHRÄGSITZVENTILE VANNE A PISTON

Valvole a flusso avviato doppio e semplice effetto
Disponibili in AISI 316 e Bronzo da 3/8" a 2"
Teste di comando: DN 40 - DN50 - DN 63 - DN 90 - DN110

Angle seat valves double acting or spring return versions
Available in AISI 316 or Bronze from 3/8" to 2"
Control head: DN 40 - DN50 - DN 63 - DN 90 - DN110

Vanne a comande par piston double et simple effet
Serie in acier AISI 316 ou Bronze de 3/8" à 2"
Tetes de commande: DN 40 - DN50 - DN 63 - DN 90 - DN110

Doppelt- bzw einfachwirkende Schrägsitzventile
Gehäuse in AISI 316 und Rotguß von 3/8" bis 2"
Steuerkopf: DN 40 - DN50 - DN 63 - DN 90 - DN110



VIP

Valvola di intercettazione pneumatica doppio e semplice effetto
Disponibili in ottone da 3/8" a 2"

Automated ON-OFF valve
Realised in double acting or spring return versions
Available in brass from 3/8" to 2"

Vanne pilotée de 3/8" à 2", en Laiton

Pneumatisch gestenertes Messing Sperrventil
von 3/8" bis 2"

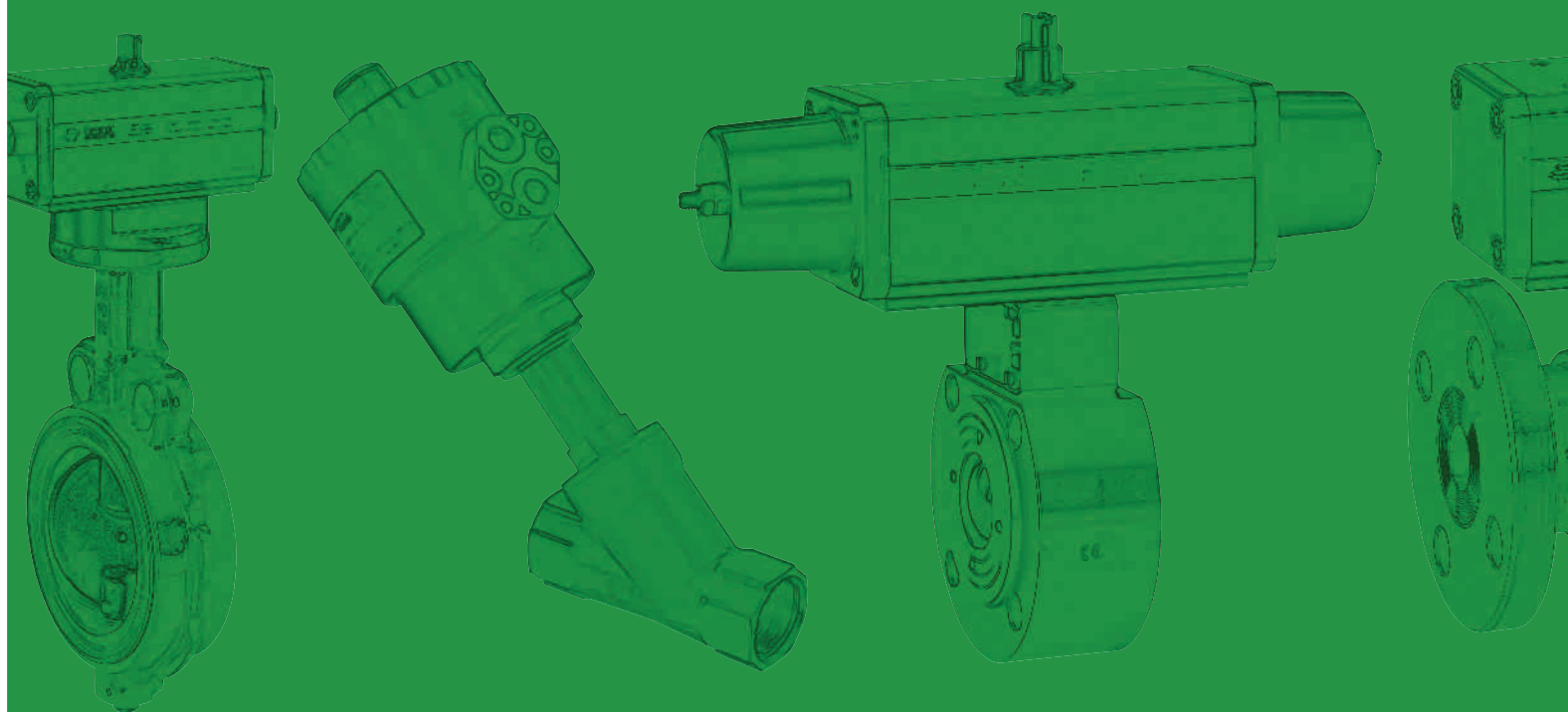

OMAL S.P.A.

Via Ponte Nuovo, 11 25050 Rodengo Saiano Brescia Italy - Tel. +390308900145 r.a.
<http://www.omal.com> - <http://www.omal.it> - E-mail: omal@omal.com