

The connectivity of the QUASAR rectifiers to the industrial network Profibus-DP is accomplished through the CRS Profibus-DP communication adapter (Part Number: PFB002). It is composed of a 2 layers PCB electronic card that uses a chip module from HMS called AnyBus-IC, which integrates all the required hardware and software for Profibus-DP connectivity.

The PFB002 is mounted on the backside of the rectifier's top cover, near the CPU card.

Main Components

1. Flat cable 9 pin female for connection to CPU card (CBF301)
2. Modbus 9 pin Sub-D male connector - RS323 interface to QUASAR
3. Profibus-DP 9 pin Sub-D female connector
4. Front plate (8250-50-017)
5. PCB electronic card for Profibus-DP (PFB100)
6. HMS Profibus-DP bridge module (8260-029)

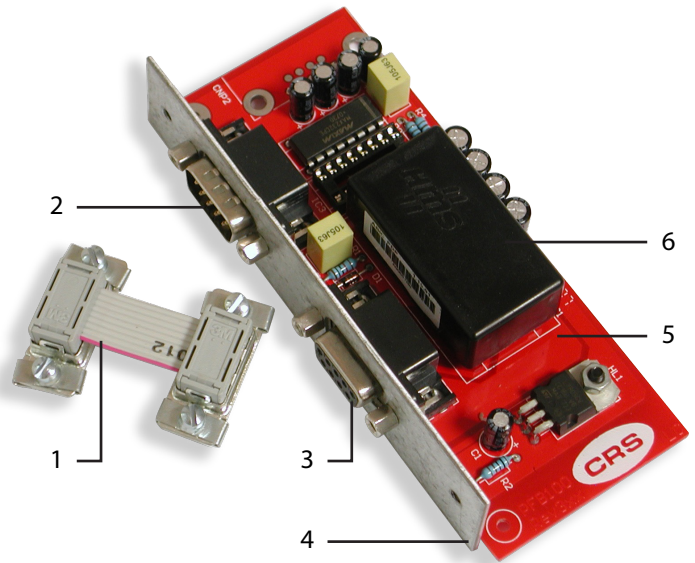

Revisions

PFB002 - Revision: A

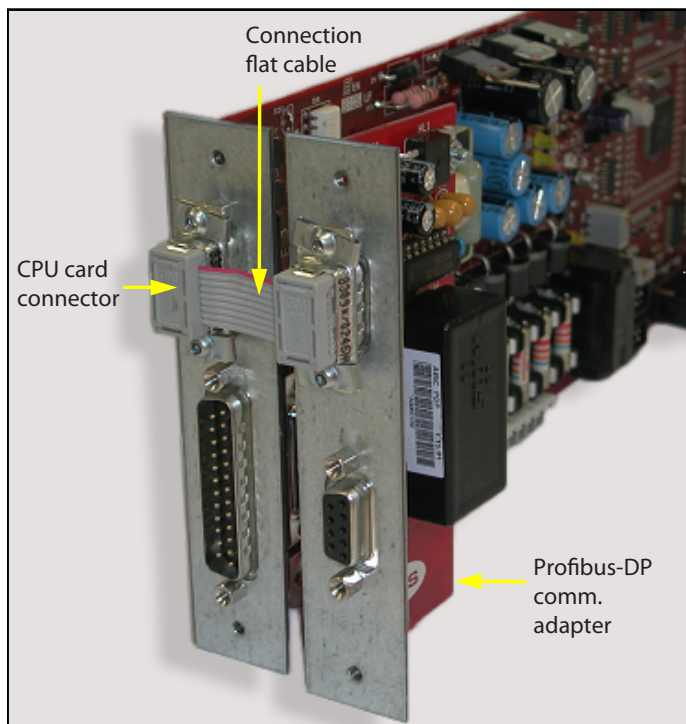

PFB002 - Revision: B

Includes status indicators

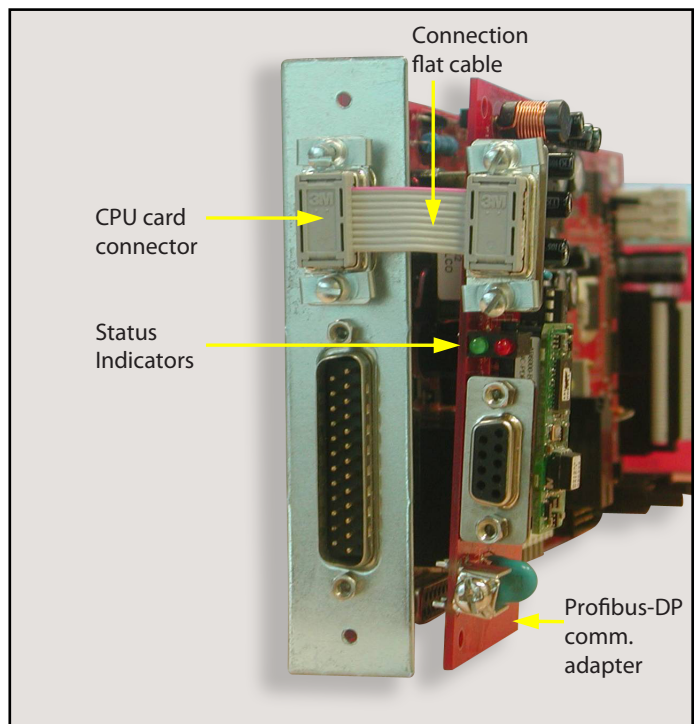

STATUS INDICATORS - PFB002 (Revision: B)

INDICATOR	STATUS	MEANING
Green LED	OFF	Node OFF-LINE or power not supplied
Green LED	ON	Node ON-LINE (Normal status)
Green LED	FLASHING 1 Hz	Node in clear mode
Red LED	OFF	No error (Normal status) or power not supplied
Red LED	ON	Error on initialization of Profibus ASIC
Red LED	FLASHING 1 Hz	Error in configuration data and/or user parametrization data

CONNECTION TABLES

Profibus-DP connector is a 9 pin Sub-D female connector.

1	NOT USED
2	NOT USED
3	BLine line
4	NOT USED
5	GND Bus from HMS module
6	+5V Bus from HMS module (max. 100mA, NOT short circuit protected)
7	NOT USED
8	ALine line
9	PE, also on connector housing

MEMORY IMAGES – DC / DCR MACHINES

Input Area

Legend: SWORD = 16 bits signed, UWORD = 16 unsigned, UDWORD = unsigned 32 bits

BYTE OFFSET	SIZE	WORD NAME	DESCRIPTION
0000	UWORD	MAX_AMPERE	Ampere maximum output rating
0002	UWORD	MAX_VOLT	Volt maximum output rating
0004	UWORD	Q_STATUS	Status register
0006	SWORD	ACT_AMPERE	Current reading
0008	SWORD	ACT_VOLT	Voltage reading
000A	UDWORD	PARTIAL_AH	Partial ampere/hour counter
000E	UDWORD	TOTAL_AH	Total ampere/hour counter
0012	UWORD	ELAPSED_TIME	Elapsed time in seconds

Output Area

BYTE OFFSET	SIZE	WORD NAME	DESCRIPTION
0000	UWORD	CMD_REG	Command register
0002	SWORD	SET_AMPERE	Setpoint ampere
0004	SWORD	SET_VOLT	Setpoint volt

Status Register Word (Input Address 0004)

BIT	DESCRIPTION		MASK
0	1 = Started	0 = Stopped (Stand-by)	0001
1	1 = Automatic mode	0 = Manual mode	0002
2	1 = Voltage mode	0 = Current mode	0004
3	1 = Main power out of specs	0 = Main power OK	0008
4	1 = Power modules problem	0 = Power modules OK	0010
5	1 = Thermal protection	0 = Temperature OK	0020
6	1 = POWERED ON	0 = NOT POWERED ON	0040
7	1 = With inversion feature	0 = W/O inversion feature	0080
8	1 = Ampere constant-> 10	0 = Ampere constant -> 1	0100
9	1 = A/m	0 = A/H	0200
10	1 = Data error	0 = Data OK	0400
11	1 = Invalid operation	0 = Operation OK	0800
12-15	NOT USED		

Note:

- 'Data error' bit is set if ampere and volt setpoints are not consistent (i.e. not of the same sign).
- 'Invalid operation' bit is set if trying to modify the output area in manual mode.

Command Register Word (Output Address 0000)

BIT	DESCRIPTION		MASK
0	1 = START	0 = STOP (Stand-by)	0001
1	1 = Automatic mode	0 = Manual mode	0002
2-6	NOT USED		
7	1 = Clear total ampere meter	0 = Total ampere meter running	0080
8-15	NOT USED		

Note:

Total ampere meter will be cleared upon bit 7 transaction from 1 to 0.

MEMORY IMAGES – PP / PPR MACHINES
Input Area

Legend: **SWORD** = 16 bits signed, **UWORD** = 16 unsigned, **UDWORD** = unsigned 32 bits

WORD OFFSET	SIZE	WORD NAME	DESCRIPTION
0000	UWORD	MAX_AMPERE	Ampere maximum output rating
0002	UWORD	MAX_VOLT	Volt maximum output rating
0004	UWORD	Q_STATUS	Status register
0006	SWORD	AVG_AMPERE	Current average reading
0008	SWORD	AVG_VOLT	Voltage average reading
000A	SWORD	ACT_AMPERE1	Current reading pulse n.1
000C	SWORD	ACT_VOLT1	Voltage reading pulse n.1
000E	SWORD	ACT_AMPERE2	Current reading pulse n.2
0010	SWORD	ACT_VOLT2	Voltage reading pulse n.2
0012	SWORD	ACT_AMPERE3	Current reading pulse n.3
0014	SWORD	ACT_VOLT3	Voltage reading pulse n.3
0016	SWORD	ACT_AMPERE4	Current reading pulse n.4
0018	SWORD	ACT_VOLT4	Voltage reading pulse n.4
001A	UWORD	PARTIAL_AH	Partial ampere meter counter
001C	UDWORD	TOTAL_AH	Total ampere meter counter

Output Area

WORD OFFSET	SIZE	WORD NAME	DESCRIPTION
0000	UWORD	CMD_REG	Command register
0002	UWORD	RAMPS_MODE	Ramp seconds / Mode amp/volt
0004	SWORD	SET_AMPERE1	Setpoint ampere pulse n.1
0006	SWORD	SET_VOLT1	Setpoint volt pulse n.1
0008	SWORD	TIME1	Pulse n.1 milliseconds
000A	SWORD	SET_AMPERE2	Setpoint ampere pulse n.2
000C	SWORD	SET_VOLT2	Setpoint volt pulse n.2
000E	SWORD	TIME2	Pulse n.2 milliseconds
0010	SWORD	SET_AMPERE3	Setpoint ampere pulse n.3
0012	SWORD	SET_VOLT3	Setpoint volt pulse n.3
0014	SWORD	TIME3	Pulse n.3 milliseconds
0016	SWORD	SET_AMPERE4	Setpoint ampere pulse n.4
0018	SWORD	SET_VOLT4	Setpoint volt pulse n.4
001A	SWORD	TIME4	Pulse n.4 milliseconds

Note:

- Word at offset 0002 has to be considered as 2 bytes. The leftmost (MSB, mask 0xFF00) is the ramp time in seconds (max 30 seconds), the rightmost byte (LSB, mask 0x00FF) is the ampere/volt pulse drive mode select: 1=volt, 0=ampere.
- Minimum pulse allowed time in milliseconds is 5.
- Examples for above word:
 - 0x1401: ramp 20 seconds, volt drive mode.
 - 0x0A00: ramp 10 seconds, current drive mode.

Status Register Word (Input Address 0004)

BIT	DESCRIPTION		MASK
0	1 = Started	0 = Stopped (Stand-by)	0001
1	1 = Automatic mode	0 = Manual mode	0002
2	1 = Voltage mode	0 = Current mode	0004
3	1 = Main power out of specs	0 = Main power OK	0008
4	1 = Power modules problem	0 = Power modules OK	0010
5	1 = Thermal protection	0 = Temperature OK	0020
6	1 = POWERED ON	0 = NOT POWERED ON	0040
7	1 = With inversion feature	0 = W/O inversion feature	0080
8-11	Number of defined pulses		0F00
12	1 = Over limits	0 = NOT over limits	1000
13	1 = Pulsing mode	0 = DC mode	2000
14	1 = Data error	0 = Data OK	4000
15	1 = Invalid operation	0 = Operation OK	8000

Note:

- 'Data error' bit is set if no valid setpoints or pulse value is defined (i.e: current setpoint and voltage setpoint not of the same sign; pulse time less than allowed minimum milliseconds).
- 'Invalid operation' bit is set if trying to modify the output area in manual mode

Command Register Word (Output Address 0000)

BIT	DESCRIPTION		MASK
0	1 = START	0 = STOP (Stand-by)	0001
1	1 = Automatic mode	0 = Manual mode	0002
2	1 = Pulse mode	0 = DC mode	0004
3-6	NOT USED		
7	1 = Clear total ampere meter	0 = Total ampere meter running	0080
8-15	NOT USED		

Note:

- When running in DC mode, current and voltage setpoints are taken from pulse n.1 setpoints; pulse n.1 time becomes meaningless.
- Total ampere meter is cleared on bit 7 edge from 1 to 0.

QUASAR CONFIGURATION

The only parameter that must be configured on the QUASAR rectifiers is 'PRFBUS NODE' (Profibus-DP node ID), which is found inside 'CONTROL PARMS' menu. A numeric value from 1 to 99 must be set.

The Profibus-DP adapter supports automatic baud rate detection, which means that the actual baud rate is only configured in the Profibus network master PLC.

AnyBus-IC® is a registered trademark of HMS FIELDBUS SYSTEMS AB.
All other trademarks are property of their respective holders.

