



COMPANY

Zoeller Family of Water Solutions™

50 Hz Products

Utility Pumps

Sump / Effluent Pumps

Sewage Pumps

Grinder Pumps

Specialty Products

Accessories

Controls



Your Peace of Mind is Our Top Priority®

WHAT SETS ZOELLER PUMPS APART?

Since 1939, Zoeller Company has been manufacturing water pumps of many types. From pedestal pumps in the beginning to large HP, submersible, non-clog pumps in recent years, we have gained invaluable manufacturing experience from our humble beginning in August Zoeller's basement workshop.

Over the years, one of our most important mottos has been, 'We excel at 1,000 little things'. From start to finish, we take pride in our products. When you have residential or commercial wastewater issues, you can count on Zoeller to deliver the very best solutions. Our commitment to unsurpassed quality offers years of service and durability with a responsive and knowledgeable product support team just a phone call away.

- **MANUFACTURING IS IN OUR BLOOD...**

Rather than using a 'puzzle piece' mentality and simply buying components from other sources and assembling them, we manufacture most of our products from start to finish, continually checking the quality throughout the entire process.

Quality is always the most important element at Zoeller. Above all, quality is what has made us successful and continues to drive the decisions we make. A quality product cannot be manufactured with low-grade components. By bringing in high-quality raw castings as well as machining and powder coating the pieces in house, we are able to control the quality of each part and identify any defect throughout the manufacturing process. Each piece is subjected to numerous quality checkpoints along the way to guarantee that it is the best of the best.

- **FACTORY TESTING IS NOT JUST A BUZZWORD...**

Instead of running 'audits' on a calculated number of pumps, all submersible Zoeller pumps are 100% factory tested underwater prior to shipment. Each pump is subjected to a leak test to ensure that all gaskets, seals and mating surfaces will hold under pressure. After the pressurized leak test, the pump is powered up and run underwater to ensure that it is capable of the published head capacity and flow rate listed in our catalog and specification sheets. This testing allows us to guarantee the pump will operate out of the box every time, and you can rest assured that YOUR Zoeller pump was tested underwater for both electrical and hydraulic performance.

- **FULL BREADTH OF PRODUCT LINE...**

Zoeller is your 'one stop shop' when dealing with dewatering and wastewater systems. We offer everything from a small fractional sump pump to a large, 100 HP, non-clog pump. From battery back-ups, check valves, sewage grinder systems, small prepackaged residential units or large prepackaged municipal systems, Zoeller can offer it all. Next time you are looking for a water or wastewater system, reach for the only catalog you will ever need... Zoeller Company!



PRODUCT INDEX

COMPOSITE PUMP CURVES	4
UTILITY	Model 42	5
	Model 47	6
SUMP / EFFLUENT	Model 49, 70	7
	Model 53, 55	8
	Model 72	9
	Model 86	10
	Model 88	11
	Model 98	12
	Model 137, 139	13
	Model 140/4140, 145/4145	14
	Model 152, 153	15
	Model 161, 162, 163, 165	16
	Model 185, 189	17
SEWAGE	Model 222	18
	Model 264	19
	Model 266, 267, 268	20
	Model 270/4270, 271/4271	21
	Model 282	22
	Model 292, 293, 294	23
GRINDER	Model 840, 841	24
SPECIALTY	Model 912 Prepackaged System	25
	Model 105, 135 Drain Pump	26, 27
	Model 371, 372, 373 Evaporative Pump	28
	Model 4290, 4291 Agriculture Pump	29
	Model 202 Qwik Jon® Ultima	30, 31
	Model 941 Oil Guard®	32, 33
ACCESSORIES	34, 35
CONTROL PANELS	36, 37
PLUG TYPES	37

Composite Pump Curves

SUMP / EFFLUENT

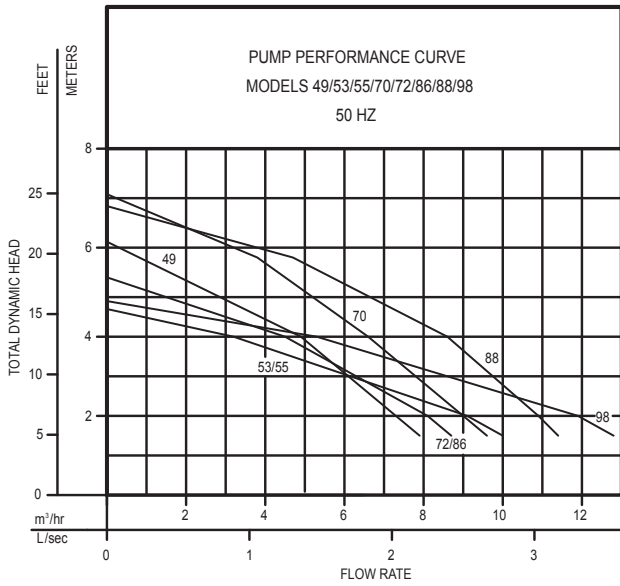

EFFLUENT

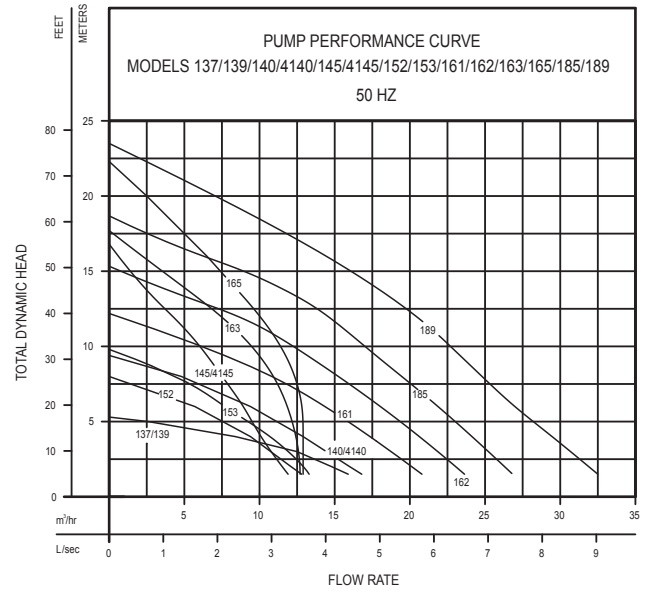

152100

SEWAGE

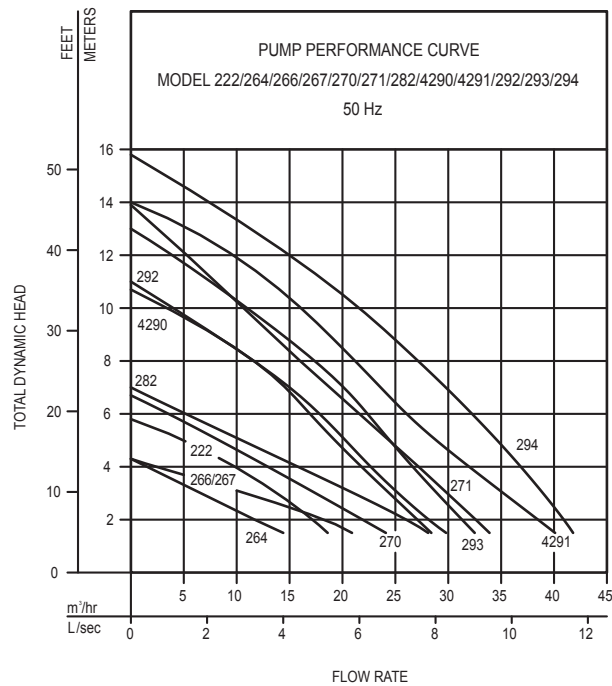

151888

Your Peace of Mind is Our Top Priority®



FEATURES:

- Engineered thermoplastic and stainless steel components provide improved corrosion resistance.
- Vent hole prevents air lock
- Carrying handle for easy installation and removal
- Removable screened bottom for easy cleaning

APPLICATIONS: (for mostly clear water)

- Garden spraying
- Lake / river water transfer
- Rainwater removal
- Basement water removal

OPTIONAL:

- Additional cord lengths available in 6 m (20') or 10 m (33').
- Available with a 2 m (8') cord and a type G plug.

* Power cords less than 10 m (33') are intended for indoor use only.

Nonautomatic Design

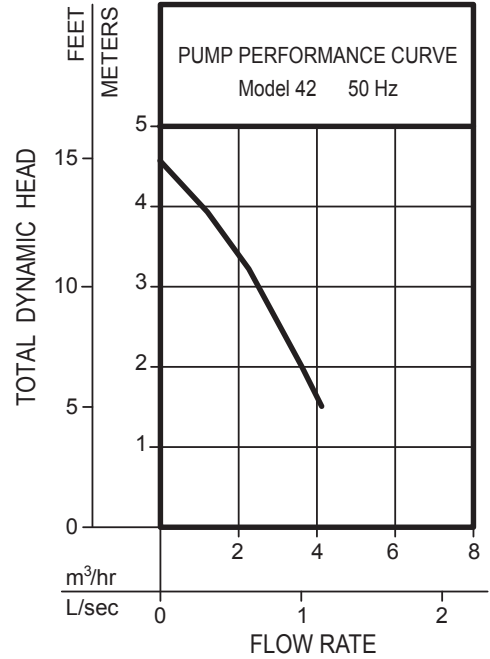
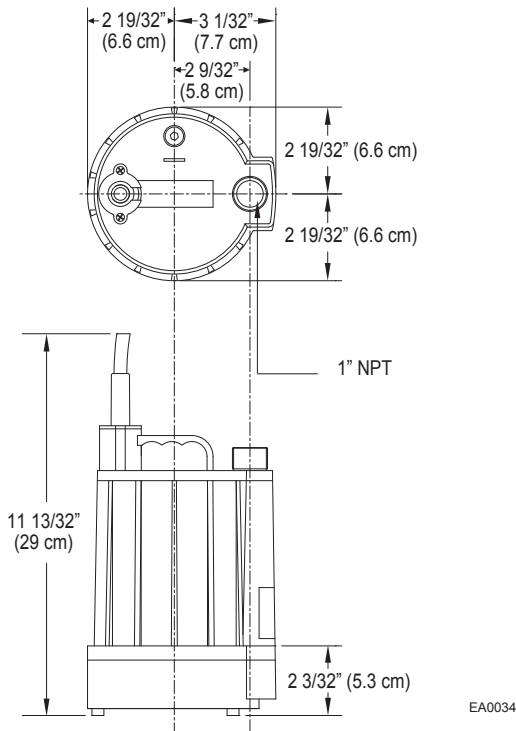

081155

PUMP		Material	
	Pump Housing	Glass-filled polypropylene	
	Impeller	Engineered plastic	
	Shaft Seal	Carbon and ceramic	
	Seal and gasket	NBR	
	Power Cord	H07RN-F	
MOTOR		Design Features	
	Impeller	Non-clogging vortex	
	Bearings	Ball bearing upper/lower	
	Power Cord Length	3 m (9') standard	
	Motor Housing	Engineered thermoplastic	
	Type	Permanent split capacitor	
	RPM	2800	
	Insulation Class	B	
	Motor Protection	Auto reset thermal overload	
	Protection Class	IPX8	
	Cooling	Oil free	
	Maximum Fluid Temperature	40°C (104°F)	
	Discharge Size	1" NPT	
	Max. Submersion Depth	6 m (20')	
	Hardware	Stainless steel	
	Pumps Floor Dry	3 mm (1/8")	



Model	Mode	Volt	Ph	Amp	Motor		Weight	
Single Seal					KW (p1)	HP	Kg.	Lbs.
V42	Non	220	1	0.6	0.14	1/6	4	9



FEATURES:

- Engineered plastic and stainless steel components provide improved corrosion resistance.
- Vent hole prevents air lock
- Carrying handle for easy installation and removal
- Removable screened bottom for easy cleaning

APPLICATIONS:

- Wastewater drainage
- Water supply for agricultural irrigation and landscape
- Construction site water removal
- Lake / river water transfer
- Basement water removal

OPTIONAL:

- Additional cord lengths available in 6 m (20') or 10 m (33').
- Available with a 2 m (8') cord and a type G plug.

* Power cords less than 10 m (33') are intended for indoor use only.

Nonautomatic Design

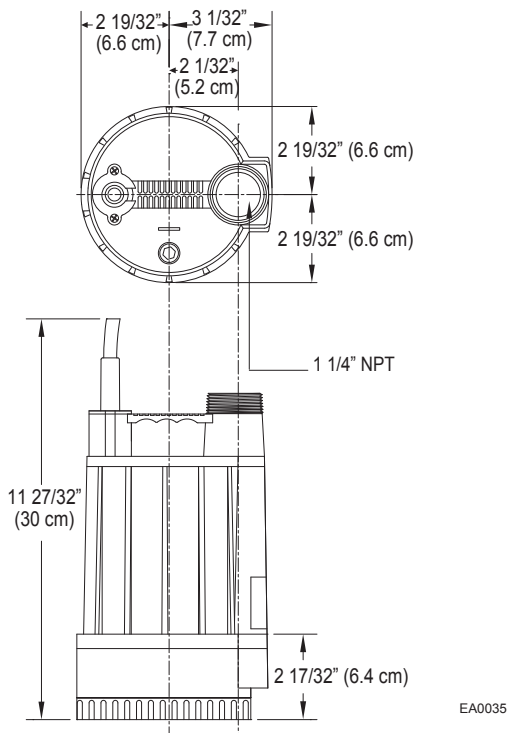

Model	Single Seal	Mode	Volt	Ph	Amp	Motor		Weight	
						KW (p1)	HP	Kg.	Lbs.
V47	Non	220	1	1.4	0.32	1/3	5	11	

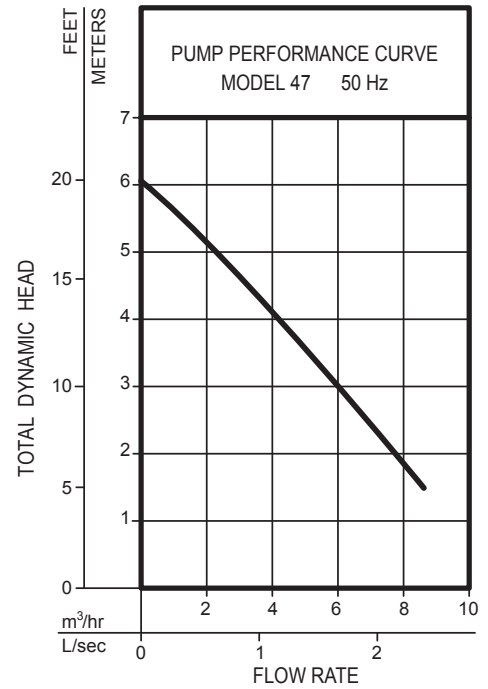

081206

PUMP	Material	
	Pump Housing	Glass-filled polypropylene
	Impeller	Engineered plastic
	Shaft Seal	Carbon and ceramic
	Seal and gasket	NBR
	Power Cord	H07RN-F
MOTOR	Design Features	
	Impeller	Non-clogging vortex
	Bearings	Ball bearing upper/lower
	Power Cord Length	3 m (9') standard
	Motor Housing	Engineered thermoplastic
	Type	Permanent split capacitor
	RPM	2800
	Insulation Class	B
	Motor Protection	Auto reset thermal overload
	Protection Class	IPX8
Cooling	Oil filled	
Maximum Fluid Temperature		40°C (104°F)
Discharge Size		1 1/4" NPT
Max. Submersion Depth		6 m (20')
Hardware		Stainless steel

49, 70



FEATURES:

- Cast iron motor housing with rust-resistant, baked-on enamel finish to provide great heat dissipation
- Recessed, non-clogging vortex impeller design provides great solids-passing capability
- Carrying handle for easy installation and removal
- Removable screened bottom for easy cleaning

APPLICATIONS:

- Sump/effluent handling
- Dewatering
- Water transfer

OPTIONAL:

- Additional cord lengths available in 8 m (25'), 11 m (35') and 15 m (50').
 - Available with a 2 m (8') cord and a type G plug.
- * Power cords less than 10 m (33') are intended for indoor use only.

Automatic Design

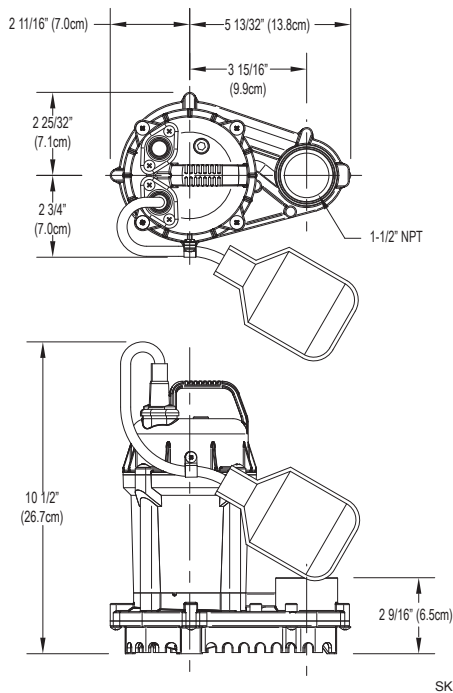

SK2635

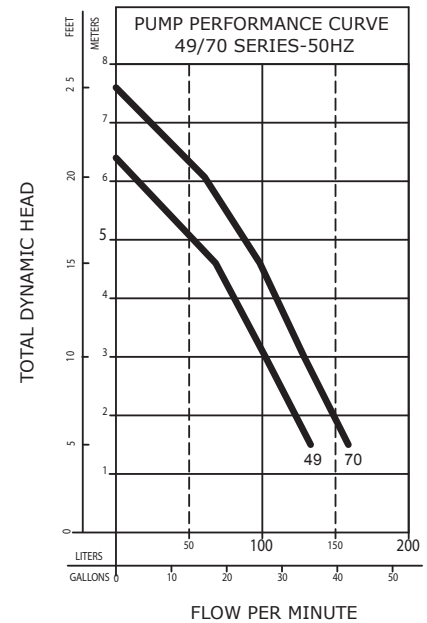

081152

Model	Single Seal	Mode	Volt	Ph	Amp	Motor		Weight	
						KW (p1)	HP	Kg.	Lbs.
WU49		Auto	220	1	1.6	0.36	1/4	5	11
V49		Non	220	1	1.6	0.36	1/4	5	11
WU70		Auto	220	1	2.2	0.45	1/3	5	11
V70		Non	220	1	2.2	0.45	1/3	5	11

PUMP	Material	
	Pump Housing	Glass-filled polypropylene
	Impeller	Engineered plastic
	Shaft Seal	Carbon and ceramic
	Seal and gasket	NBR
	Power Cord	SOW/SOOW (CE model H07RN-F)
	Design Features	
	Impeller	Non-clogging vortex
	Bearings	Ball bearing upper/lower
	Solid Passing	9 mm (3/8") spherical solids
Power Cord Length	3 m (9') standard	
MOTOR	Motor Housing	Cast iron
	Type	Permanent split capacitor
	RPM	2800
	Rotor	SAE 1117 carbon steel
	Insulation Class	B
	Motor Protection	Auto reset thermal overload
	Protection Class	IPX8
	Cooling	Oil filled
Maximum Fluid Temperature		40°C (104°F)
Discharge Size		1 1/2" NPT
Max. Submersion Depth		6 m (20')
Hardware		Stainless steel
On/Off Point		28.6 cm (11 1/4") / 10.5 cm (4 1/8")

53, 55



FEATURES:

- Cast iron construction with powder coated epoxy finish
- Designed to provide great heat dissipation
- Recessed, non-clogging vortex impeller design provides great solids-passing capability
- Solid, buoyant polypropylene float
- Model 53 features a cast iron switch case, motor and pump housing and a glass-filled plastic impeller.
- Model 55 features a bronze switch case, motor and pump housing and a glass-filled plastic impeller.

APPLICATIONS:

- Sump/effluent handling
- Dewatering
- Water transfer

Automatic Design

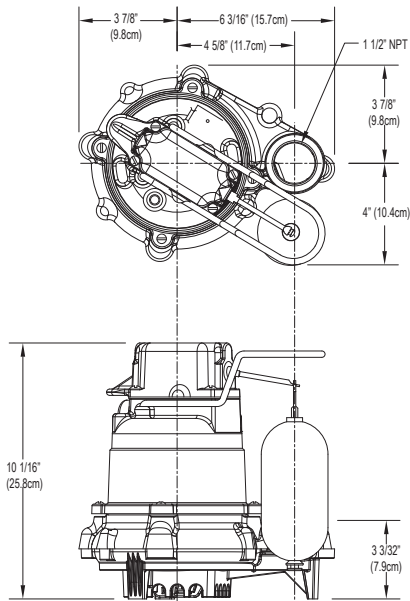

SK858



Model	Mode	Volt	Ph	Amp	Motor		Weight	
					KW (p1)	HP	Kg.	Lbs.
U53	Auto	220	1	5.2	0.72	3/10	10	22
V53	Non	220	1	5.2	0.72	3/10	10	22
U55	Auto	220	1	5.2	0.72	3/10	14	31
V55	Non	220	1	5.2	0.72	3/10	14	31

OPTIONAL:

- Additional cord lengths available in 8 m (25'), 11 m (35') and 15 m (50').
- Available with a type E/F (5 or 10 m), G (2 or 10 m) or I (5 m) plug.

* Power cords less than 10 m (33') are intended for indoor use only.

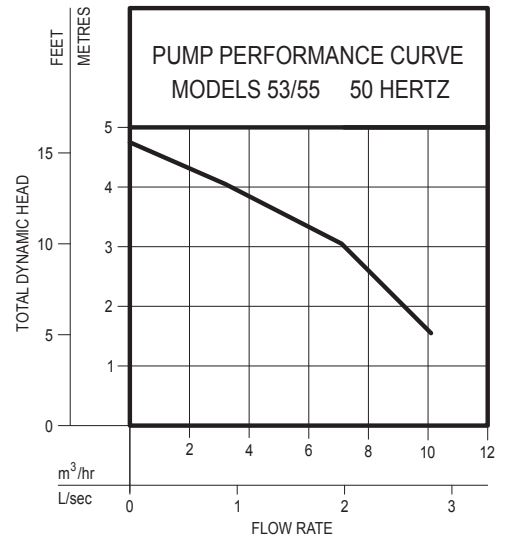

009942

		Material	
PUMP	Pump Housing	Cast iron or bronze	
	Impeller	Glass-filled plastic	
	Shaft Seal	Carbon and ceramic	
	Seal and gasket	Neoprene	
	Power Cord	SOW/SOOW (CE model H07RN-F)	
			Design Features
MOTOR	Impeller	Non-clogging vortex	
	Bearings	Sleeve bearing upper/lower	
	Solid Passing	12 mm (½") spherical solids	
	Power Cord Length	3 m (9') standard	
	Motor Housing	Cast iron or bronze	
	Type	Shaded pole	
	RPM	1300	
	Rotor	AISI 1215 cold roll steel	
	Insulation Class	B	
	Motor Protection	Auto reset thermal overload	
Protection Class	IPX8		
Cooling	Oil filled		
Maximum Fluid Temperature		54°C (130°F)	
Discharge Size		1½" NPT	
Max. Submersion Depth		6 m (20')	
Hardware		Stainless steel	
On/Off Point		18.4 cm (7¼") / 7.6 cm (3")	



FEATURES:

- Non-corrosive engineered plastic design
- Hermetically sealed for complete submersion
- Recessed, non-clogging vortex impeller design provides great solids-passing capability
- Solid, buoyant polypropylene float

APPLICATIONS:

- Sump/effluent handling
- Dewatering
- Water transfer

OPTIONAL:

- Available with a 2 m (8') cord and a type G plug.

* Power cords less than 10 m (33') are intended for indoor use only.

Automatic Design

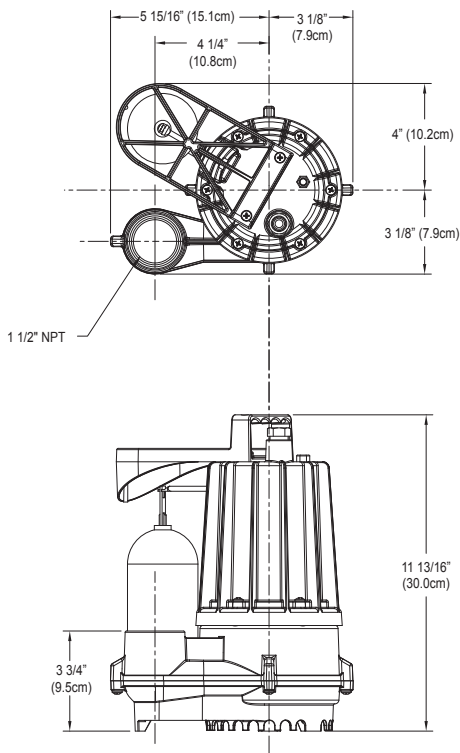

SK1924



Model	Mode	Volt	Ph	Amp	Motor		Weight	
					KW (p1)	HP	Kg.	Lbs.
U72	Auto	220	1	2.0	0.38	3/10	4	9
V72	Non	220	1	2.0	0.38	3/10	5	10

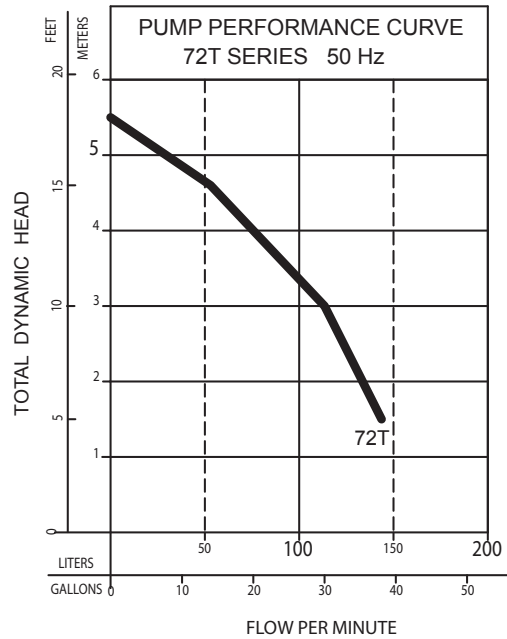

081205

		Material	
PUMP	Pump Housing	Engineered plastic	
	Impeller	Engineered plastic	
	Shaft Seal	Carbon and ceramic	
	Seal and gasket	Buna-N	
	Power Cord	SOW / SOOW (CE model H07NR-F)	
		Design Features	
MOTOR	Impeller	Non-clogging vortex	
	Bearings	Ball bearing upper/lower	
	Solid Passing	9 mm (3/8") spherical solids	
	Power Cord Length	3 m (9') standard	
	Motor Housing	Engineered thermoplastic	
	Type	Permanent split capacitor	
	RPM	2800	
	Rotor	SAE 1117 carbon steel	
	Insulation Class	B	
	Motor Protection	Auto reset thermal overload	
Protection Class	IPX8		
Cooling	Oil free		
Maximum Fluid Temperature		43°C (110°F)	
Discharge Size		1 1/2" NPT	
Max. Submersion Depth		6 m (20')	
Hardware		Stainless steel	
On/Off Point		18.7 cm (7 3/8") / 9.2 cm (3 5/8")	



FEATURES:

- Cast iron motor housing with rust-resistant, baked-on enamel finish to provide great heat dissipation
- Engineered plastic and stainless steel components provide improved corrosion resistance.
- Vent hole prevents air lock
- Lifting handle for easy installation and removal

APPLICATIONS:

- Wastewater drainage
- Water supply for agriculture irrigation and landscape
- Construction site water removal
- Basement water removal
- Lake / river water transfer

OPTIONAL:

- Additional cord lengths available in 6 m (20') or 10 m (33').
- Available with a 2 m (8') cord and a type G plug.

* Power cords less than 10 m (33') are intended for indoor use only.

Automatic Design

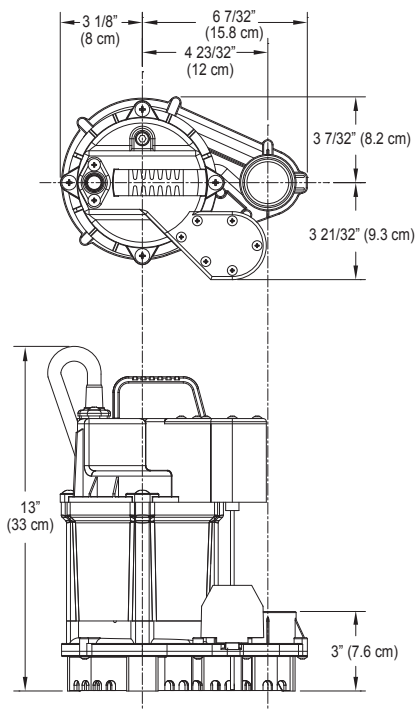

EA0037



Model	Mode	Volt	Ph	Amp	Motor		Weight	
					KW (p1)	HP	Kg.	Lbs.
U86	Auto	220	1	1.9	0.39	1/3	8	18
WU86	Auto	220	1	1.9	0.39	1/3	8	18
V86	Non	220	1	1.9	0.39	1/3	8	18

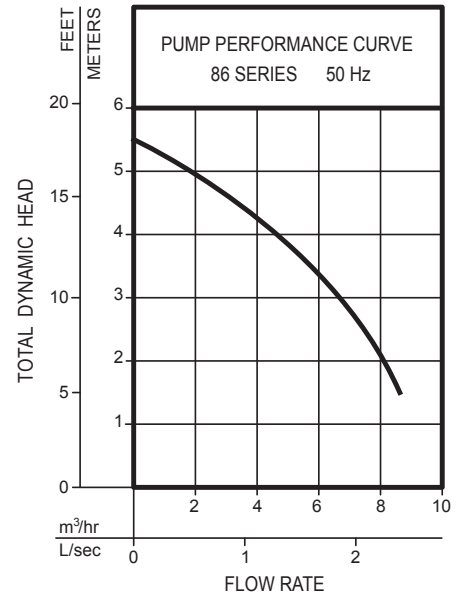

081208

PUMP		Material	
	Pump Housing	Engineered plastic	
	Impeller	Engineered plastic	
	Shaft Seal	Carbon and ceramic	
	Seal and gasket	NBR	
	Power Cord	H07RN-F	
PUMP		Design Features	
	Impeller	Non-clogging vortex	
	Bearings	Ball bearing upper/lower	
	Solid Passing	9 mm (3/8") spherical solids	
	Power Cord Length	3 m (9') standard	
MOTOR		Material	
	Motor Housing	Cast iron	
	Type	Permanent split capacitor	
	RPM	2800	
	Insulation Class	B	
	Motor Protection	Auto reset thermal overload	
	Protection Class	IPX8	
	Cooling	Oil filled	
Maximum Fluid Temperature		40°C (104°F)	
Discharge Size		1½" NPT	
Max. Submersion Depth		6 m (20')	
Hardware		Stainless steel	
On/Off Point		18 cm (7") / 10 cm (4")	



FEATURES:

- Durable cast iron motor and pump housing with rust-resistant, baked-on enamel finish to provide great heat dissipation
- Stainless steel hardware provides improved corrosion resistance.
- Vent hole prevents air lock
- Lifting handle for easy installation and removal

APPLICATIONS:

- Wastewater drainage
- Water supply for agriculture irrigation and landscape
- Construction site water removal
- Basement water removal
- Lake/river water transfer

OPTIONAL:

- Additional cord lengths available in 6 m (20') or 10 m (33').
- Available with a 2 m (8') cord and a type G plug.

* Power cords less than 10 m (33') are intended for indoor use only.

Automatic Design

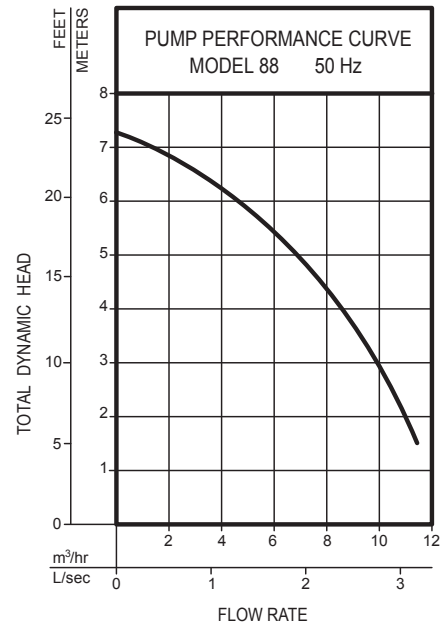
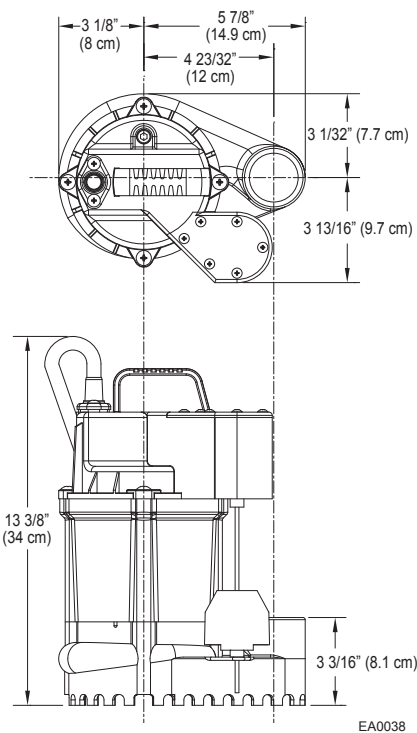

081457

PUMP	Material	
	Pump Housing	Cast iron
Impeller	Engineered plastic	
Shaft Seal	Carbon and ceramic	
Seal and gasket	NBR	
Power Cord	H07RN-F	
MOTOR	Design Features	
	Impeller	Non-clogging vortex
	Bearings	Ball bearing upper/lower
	Solid Passing	9 mm (3/8") spherical solids
	Power Cord Length	3 m (9') standard
	Motor Housing	Cast iron
	Type	Permanent split capacitor
	RPM	2800
	Insulation Class	B
	Motor Protection	Auto reset thermal overload
Protection Class	IXP8	
Cooling	Oil filled	
Maximum Fluid Temperature		40°C (104°F)
Discharge Size		1 1/2" NPT
Max. Submersion Depth		6 m (20')
Hardware		Stainless steel
On/Off Point		18 cm (7") / 10 cm (4")



Model	Single Seal	Mode	Volt	Ph	Amp	Motor		Weight	
						KW (p1)	HP	Kg.	Lbs.
U88	Auto	220	1	2.6	0.53	3/4	11	24	
WU88	Auto	220	1	2.6	0.53	3/4	11	24	
V88	Non	220	1	2.6	0.53	3/4	11	24	



FEATURES:

- Cast iron motor housing with powder coated epoxy finish
- Designed to provide great heat dissipation from the motor
- Recessed, non-clogging vortex impeller design provides great solids-passing capability
- Solid, buoyant polypropylene float

APPLICATIONS:

- Sump/effluent handling
- Dewatering
- Water transfer

OPTIONAL:

- Additional cord lengths available in 8 m (25'), 11 m (35') and 15 m (50').
- Available with a type E/F (5 or 10 m), G (2 or 10 m) or I (5 m) plug.

* Power cords less than 10 m (33') are intended for indoor use only.

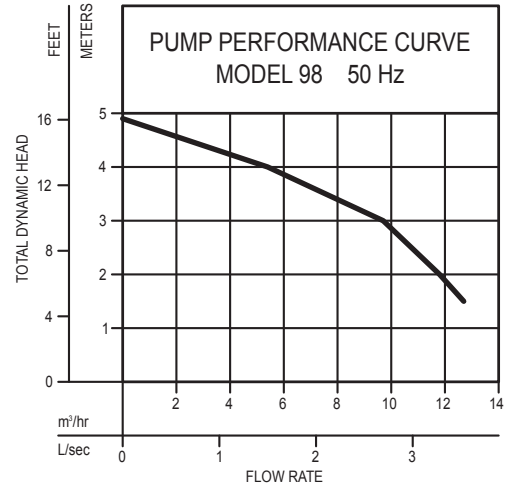

011492

Automatic Design

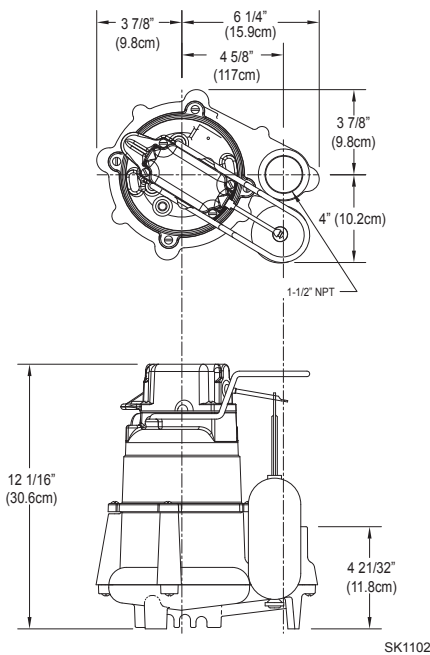

Model	Single Seal	Mode	Volt	Ph	Amp	Motor		Weight	
						KW (p1)	HP	Kg.	Lbs.
U98		Auto	220	1	4.7	0.77	1/2	16	35
V98		Non	220	1	4.7	0.77	1/2	16	35

PUMP	Material	
	Pump Housing	Cast iron
	Impeller	Engineered plastic
	Shaft Seal	Carbon and ceramic
	Seal and gasket	Neoprene
	Power Cord	SOW/SOOW (CE model H07RN-F)
	Design Features	
	Impeller	Non-clogging vortex
	Bearings	Sleeve bearing upper/lower
	Solid Passing	12 mm (½") spherical solids
Power Cord Length	3 m (9') standard	
MOTOR	Motor Housing	Cast iron
	Type	Permanent split capacitor
	RPM	1400
	Rotor	AISI 1215 cold roll steel
	Insulation Class	B
	Motor Protection	Auto reset thermal overload
	Protection Class	IPX8
	Cooling	Oil filled
Maximum Fluid Temperature		54°C (130°F)
Discharge Size		1½" NPT
Max. Submersion Depth		6 m (20')
Hardware		Stainless steel
On/Off Point		24 cm (9½") / 8 cm (3")

137, 139



FEATURES:

- Cast iron construction with powder coated epoxy finish
- Designed to provide great heat dissipation from the motor
- Recessed, non-clogging vortex impeller design provides great solids-passing capability
- Solid, buoyant polypropylene float
- Model 137 features all cast iron construction, and model 139 is all bronze.

APPLICATIONS:

- Sump/effluent handling
- Dewatering
- Water transfer

OPTIONAL:

- Extra duty option for ambient water temperature of 60°C (140°F).
- Bronze impeller available on model 137.
- Additional cord lengths available in 8 m (25'), 11 m (35') and 15 m (50').
- Available with type E/F (5 or 10 m), G (2 or 10 m) or I (5 m) plug.

* Power cords less than 10 m (33') are intended for indoor use only.

Automatic Design

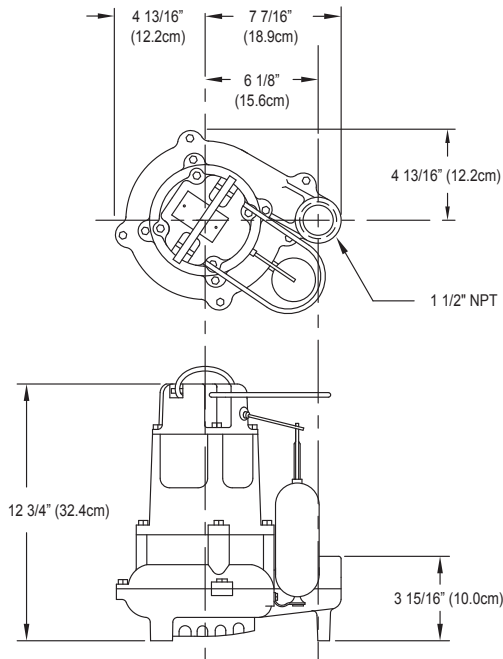

SK373

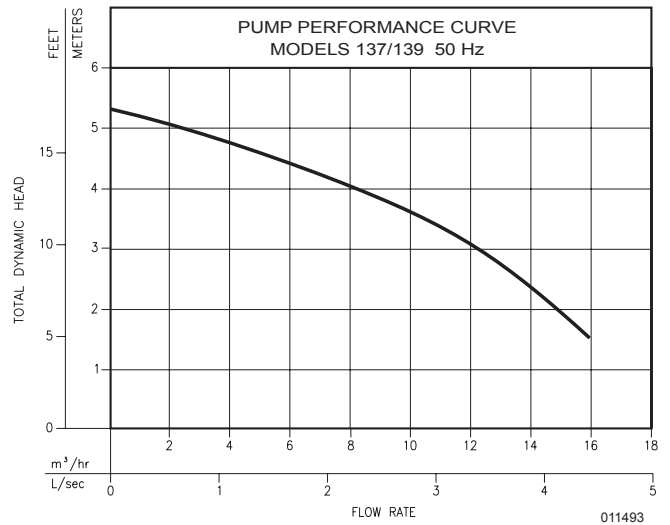

Model	Mode	Volt	Ph	Amp	Motor		Weight	
					KW (p1)	HP	Kg.	Lbs.
U137	Auto	220	1	4.2	0.7	1/2	21	46
V137	Non	220	1	4.2	0.7	1/2	21	46
AK137	Non	380	3	4.2	0.7	1/2	21	46
U139	Auto	220	1	4.2	0.7	1/2	23	51
V139	Non	220	1	4.2	0.7	1/2	23	51

PUMP		Material	
	Pump Housing	Cast iron or bronze	
	Impeller	Cast iron or bronze	
	Shaft Seal	Carbon and ceramic	
	Seal and gasket	Neoprene	
	Power Cord	SOW/SOOW (CE model H07RN-F)	
PUMP		Design Features	
	Impeller	Non-clogging vortex	
	Bearings	Sleeve, bearing upper/lower	
	Solid Passing	15 mm (5/8") spherical solids	
	Power Cord Length	3 m (9') standard	
MOTOR		Material	
	Motor Housing	Cast iron or bronze	
	Type	Split phase	
	RPM	1400	
	Rotor	AISI 1215 cold roll steel	
	Insulation Class	B	
	Motor Protection	Auto reset thermal overload (1 Ph)	
	Protection Class	IPX8	
	Cooling	Oil filled	
	Maximum Fluid Temperature	54°C (130°F)	
	Discharge Size	1 1/2" NPT	
	Max. Submersion Depth	6 m (20')	
	Hardware	Stainless steel	
	On/Off Point	25.4 cm (10") / 7 cm (2 3/4")	

140/4140, 145/4145



FEATURES:

- Cast iron motor housing with powder coated epoxy finish
- Designed to provide great heat dissipation from the motor
- Recessed, non-clogging vortex impeller design provides great solids-passing capability
- Double seal models prevent leaks and damage to seals or bearings during dry run conditions.

APPLICATIONS:

- Sump/effluent handling
- Dewatering
- Water transfer

OPTIONAL:

- Additional cord lengths available in 8 m (25'), 11 m (35') and 15 m (50').
- Available with a type E/F (5 or 10 m), G (2 or 10 m) or I (5 m) plug.

* Power cords less than 33' (10 m) are intended for indoor use only.

Single Seal Design

Double Seal Design

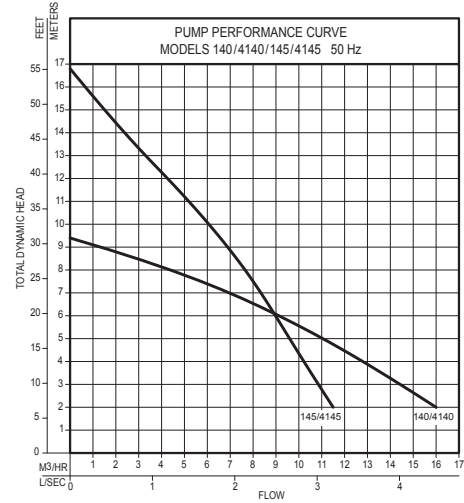
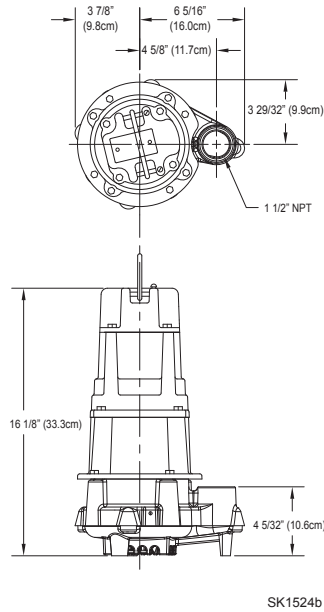
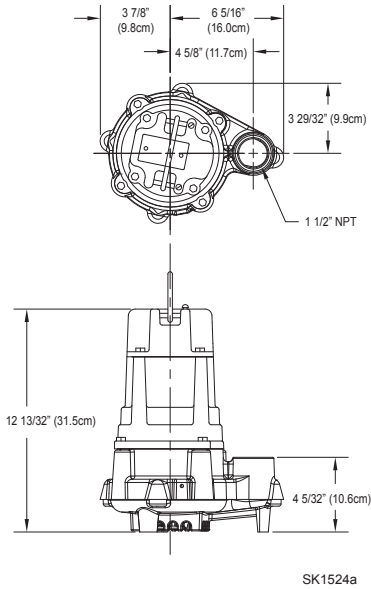

151596



Model		Mode	Volt	Ph	Amp	Motor		Weight	
Single Seal	Double Seal					KW (p1)	HP	Kg.	Lbs.
V140		Non	220	1	6.2	1.0	1	20	44
	V4140	Non	220	1	6.2	1.0	1	23	51
V145		Non	220	1	4.5	0.9	3/4	20	44
	V4145	Non	220	1	4.5	0.9	3/4	23	51

PUMP	Material	
	Pump Housing	Cast iron
	Impeller	Engineered thermoplastic
	Shaft Seal	Carbon and ceramic
	Seal and gasket	Neoprene
	Bearings	High carbon chrome steel
	Power Cord	SOW/SOOW (CE model H07RN-F)
	Design Features	
	Impeller	140: non-clogging vortex 145: single vane
	Bearings	Sleeve bearing upper/ball bearing lower
Solid Passing	140 - 12 mm (1/2") spherical solids 145 - 19 mm (3/4") spherical solids	
Power Cord Length	6 m (20') standard	
MOTOR	Motor Housing	Cast iron
	Type	Permanent split capacitor
	RPM	2800
	Rotor	AISI 1144 steel
	Insulation Class	B
	Motor Protection	Auto reset thermal overload
	Protection Class	IPX8
	Cooling	Oil filled
Maximum Fluid Temperature		54°C (130°F)
Discharge Size		1 1/2" NPT
Max. Submersion Depth		6 m (20')
Hardware		Stainless steel

152, 153



FEATURES:

- Cast iron motor housing with powder coated epoxy finish
- Designed to provide great heat dissipation from the motor
- Recessed, non-clogging vortex impeller design provides great solids-passing capability

APPLICATIONS:

- Wastewater handling
- Dewatering
- Water transfer

OPTIONAL:

- Additional cord lengths available in 8 m (25'), 11 m (35') and 15 m (50').
- Available with a type E/F (5 or 10 m), G (2 or 10 m) or I (5 m) plug.

* Power cords less than 10 m (33') are intended for indoor use only.

Nonautomatic Design

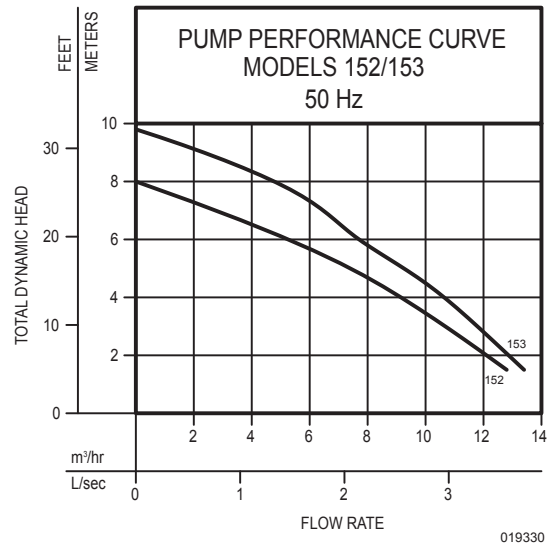
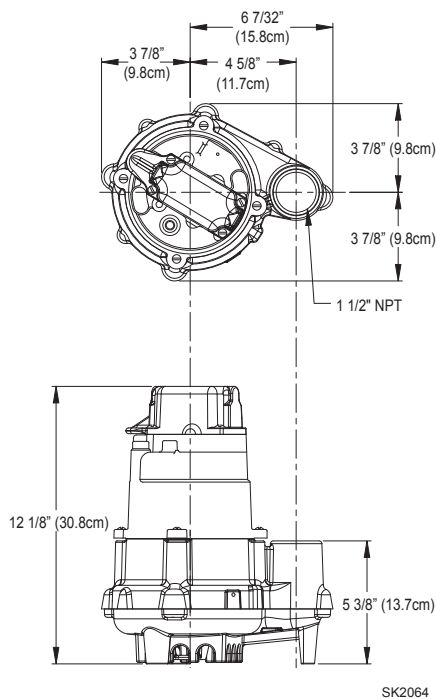

		Material		
PUMP	Pump Housing	Cast iron		
	Impeller	Engineered thermoplastic		
	Shaft Seal	Carbon and ceramic		
	Seal and gasket	Neoprene		
	Bearings	High carbon chrome steel		
	Power Cord	SOW/SOOW (CE model H07RN-F)		
			Design Features	
	Impeller	Non-clogging vortex		
	Bearings	Sleeve bearing upper/ball bearing lower		
	Solid Passing	19 mm (3/4") spherical solids		
Power Cord Length	6 m (20') standard			
MOTOR	Motor Housing	Cast iron		
	Type	Permanent split capacitor		
	RPM	2800		
	Rotor	AISI 1215 cold roll steel		
	Insulation Class	B		
	Motor Protection	Auto reset thermal overload		
	Protection Class	IPX8		
	Cooling	Oil filled		
	Maximum Fluid Temperature	54°C (130°F)		
	Discharge Size	1 1/2" NPT		
Max. Submersion Depth	6 m (20')			
Hardware	Stainless steel			



Model	Single Seal	Mode	Volt	Ph	Amp	Motor		Weight	
						KW (p1)	HP	Kg.	Lbs.
U152		Auto	220	1	3.6	0.56	4/10	17	37
V152		Non	220	1	3.6	0.56	4/10	17	37
U153		Auto	220	1	4.3	0.71	1/2	17	37
V153		Non	220	1	4.3	0.71	1/2	17	37

161, 162, 163, 165

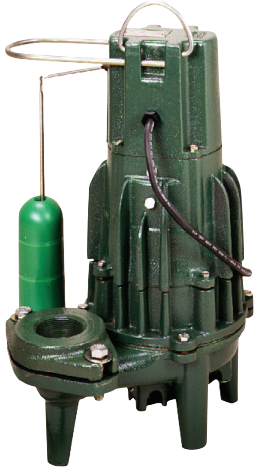

FEATURES:

- Cast iron motor housing with powder coated epoxy finish
- Finned motor housing design provides great heat dissipation
- Recessed, non-clogging vortex impeller design provides great solids-passing capability

APPLICATIONS:

- Wastewater handling
- Dewatering
- Water transfer

OPTIONAL:

- Available with a 2" or 3" NPT flange.
- Extra duty option for ambient water temperature of 60°C (140°F).
- Additional cord lengths available in 8 m (25'), 11 m (35') and 15 m (50').
- Single phase models available with a type E/F (5 or 10 m), G (2 or 10 m) or I (5 m) plug.
- CE rated AK models available with a 10 m (33') cord and no molded plug.

* Power cords less than 10 m (33') are intended for indoor use only.

Automatic Design

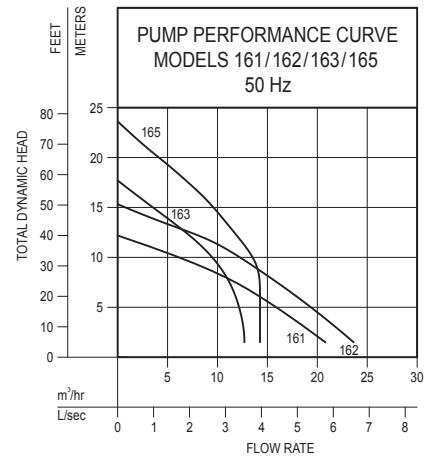
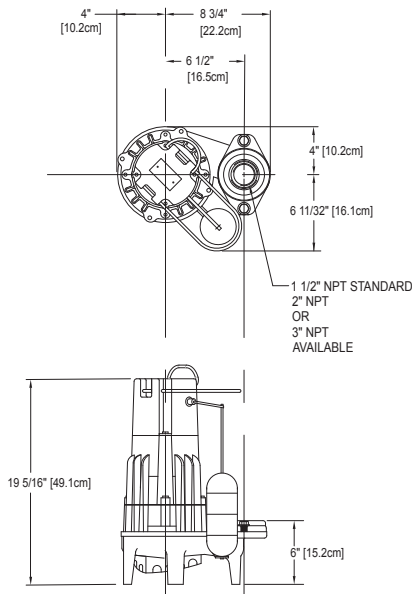

009946



SK374

Model	Single Seal	Mode	Volt	Ph	Amp	Motor		Weight	
						KW (p1)	HP	Kg.	Lbs.
U161	Auto	220	1	5.6	1.2	1/2	38	84	
V161	Non	220	1	5.6	1.2	1/2	37	82	
AK161	Non	380	3	2.0	1.2	1/2	38	84	
U162	Auto	220	1	8.0	1.7	1/2	38	84	
V162	Non	220	1	8.0	1.7	1/2	37	82	
AK162	Non	380	3	3.0	1.8	1/2	37	82	
U163	Auto	220	1	6.4	1.5	1/2	38	84	
V163	Non	220	1	6.4	1.5	1/2	38	84	
AK163	Non	380	3	2.9	1.6	1/2	37	82	
U165	Auto	220	1	9.6	2.0	1	38	84	
V165	Non	220	1	9.6	2.0	1	37	82	
AK165	Non	380	3	2.0	1.8	1	37	82	

PUMP	Material		
	Pump Housing	Cast iron	
	Impeller	Bronze	
	Shaft Seal	Carbon and ceramic	
	Seal and gasket	Neoprene	
	Bearings	High carbon chrome steel	
	Power Cord	SOW/SOOW (CE model H07RN-F)	
	MOTOR	Design Features	
		Impeller	Non-clogging vortex
		Bearings	Ball bearing upper/lower
Solid Passing		19 mm (3/4") spherical solids	
Power Cord Length		6 m (20') standard	
Motor Housing		Cast iron	
Type		Permanent split capacitor or 3 Ph	
RPM		2800	
Rotor		SAE 1117 carbon steel	
Insulation Class		B	
Motor Protection	Auto reset thermal overload (1 Ph)		
Class Protection	IPX8		
Cooling	Oil filled		
Maximum Fluid Temperature	54°C (130°F)		
Discharge Size	1 1/2" NPT		
Max. Submersion Depth	6 m (20')		
Hardware	Stainless steel		
On/Off Point	40 cm (15 3/4") / 13.3 cm (5 1/4")		

185, 189

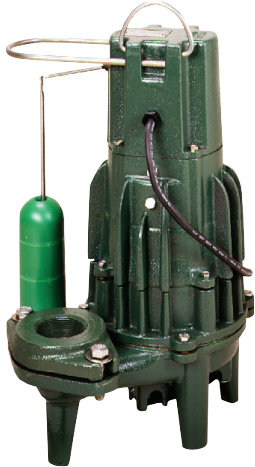

FEATURES:

- Cast iron motor housing with powder coated epoxy finish
- Finned motor housing design provides great heat dissipation
- Recessed, non-clogging vortex impeller design provides great solids-passing capability

APPLICATIONS:

- Wastewater handling
- Dewatering
- Water transfer

OPTIONAL:

- Available with a 2" or 3" NPT flange.
- Additional cord lengths available in 8 m (25'), 11 m (35') and 15 m (50').
- Single phase models available with a type E/F (5 or 10 m), G (10 m) or I (5 m) plug.
- CE rated AK models available with a 10 m (33') cord and no molded plug.

* Power cords less than 10 m (33') are intended for indoor use only.

Automatic Design

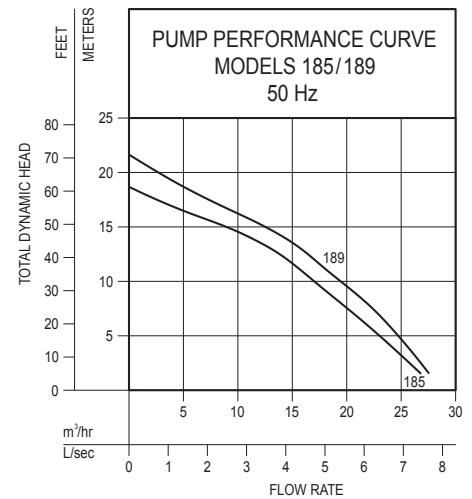
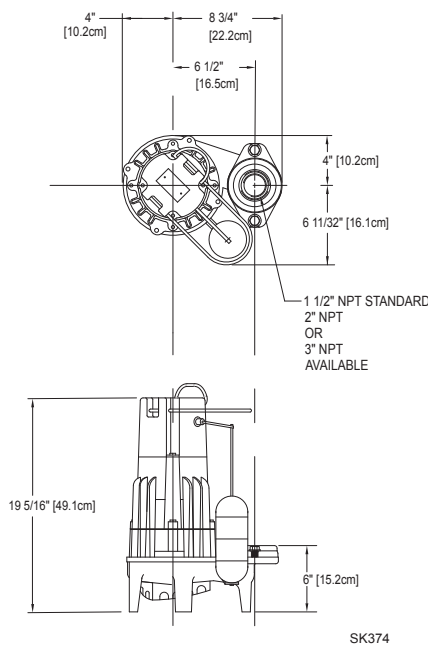

009946



Model	Single Seal	Mode	Volt	Ph	Amp	Motor		Weight	
						KW (p1)	HP	Kg.	Lbs.
U185		Auto	220	1	10.0	2.0	1	39	86
V185		Non	220	1	10.0	2.0	1	39	86
AK185		Non	380	3	4.1	2.4	1	37	82
U189		Auto	220	1	14.2	2.9	2	41	90
V189		Non	220	1	14.2	2.9	2	41	90
AK189		Non	380	3	4.5	2.6	2	37	82

PUMP	Material	
	Pump Housing	Cast iron
	Impeller	Bronze
	Shaft Seal	Carbon and ceramic
	Seal and gasket	Neoprene
	Bearings	High carbon chrome steel
	Power Cord	SOW/SOOW (CE model H07RN-F)
	Design Features	
	Impeller	Non-clogging vortex
	Bearings	Ball bearing upper/lower
Solid Passing	19 mm (3/4") spherical solids	
Power Cord Length	6 m (20') standard	
MOTOR	Motor Housing	Cast iron
	Type	Permanent split capacitor or 3 Ph
	RPM	2800
	Rotor	SAE 1117 carbon steel
	Insulation Class	B
	Motor Protection	Auto reset thermal overload (1 Ph)
	Protection Class	IPX8
	Cooling	Oil filled
Maximum Fluid Temperature		54°C (130°F)
Discharge Size		1 1/2" NPT
Max. Submersion Depth		6 m (20')
Hardware		Stainless steel
On/Off Point		40 cm (15 3/4") / 13.3 cm (5 1/4")



FEATURES:

- Cast iron motor housing with rust-resistant, baked-on enamel finish to provide great heat dissipation
- Engineered plastic and stainless steel components provide improved corrosion resistance
- Vent hole prevents air lock
- Lifting handle for easy installation and removal

APPLICATIONS:

- Residential wastewater from septic tank
- Wastewater removal from livestock areas
- Factory wastewater removal
- Wastewater containing objects removal

OPTIONAL:

- Additional cord lengths available in 6 m (20') or 10 m (33').
- Available with a type E/F (5 or 10 m), G (10 m) or I (5 m) plug.

* Power cords less than 10 m (33') are intended for indoor use only.

Automatic Design

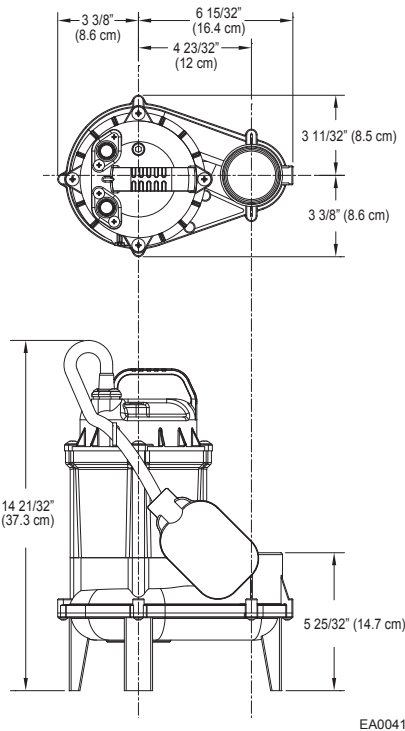

Model	Single Seal	Mode	Volt	Ph	Amp	Motor		Weight	
						KW (p1)	HP	Kg.	Lbs.
U222		Auto	220	1	3.0	0.64	3/4	9	20
WU222		Auto	220	1	3.0	0.64	3/4	9	20
V222		Non	220	1	3.0	0.64	3/4	9	20

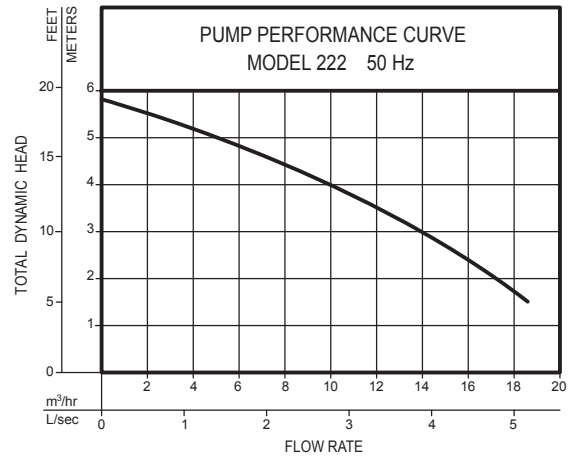

081151

PUMP	Material	
	Pump Housing	Engineered plastic
	Impeller	Engineered plastic
	Shaft Seal	Carbon and ceramic
	Seal and gasket	NBR
	Power Cord	H07RN-F
	Design Features	
	Impeller	Non-clogging vortex
	Bearings	Ball bearing upper/lower
	Solid Passing	50 mm (2") spherical solids
Power Cord Length	3 m (9') standard	
MOTOR	Motor Housing	Cast iron
	Type	Permanent split capacitor
	RPM	2800
	Insulation Class	B
	Motor Protection	Auto reset thermal overload
	Protection Class	IPX8
	Cooling	Oil filled
	Maximum Fluid Temperature	40°C (104°F)
Discharge Size	2" NPT	
Max. Submersion Depth	6 m (20')	
Hardware	Stainless steel	
On/Off Point	24 cm (9 7/16") / 14 cm (5 1/2")	



FEATURES:

- Cast iron motor housing with durable, powder coated epoxy finish
- Engineered plastic and stainless steel components provide improved corrosion resistance.
- Vent hole prevents air lock
- Lifting handle for easy installation and removal

APPLICATIONS:

- Residential wastewater removal from septic tank
- Wastewater removal from livestock areas
- Factory wastewater removal
- Wastewater containing objects removal

OPTIONAL:

- Additional cord lengths available in 8 m (25') or 11 m (35') and 15 m (50').
- Available with a type E/F (5 or 10 m), G (10 m) or I (5 m) plug.

* Power cords less than 10 m (33') are intended for indoor use only.

Automatic Design

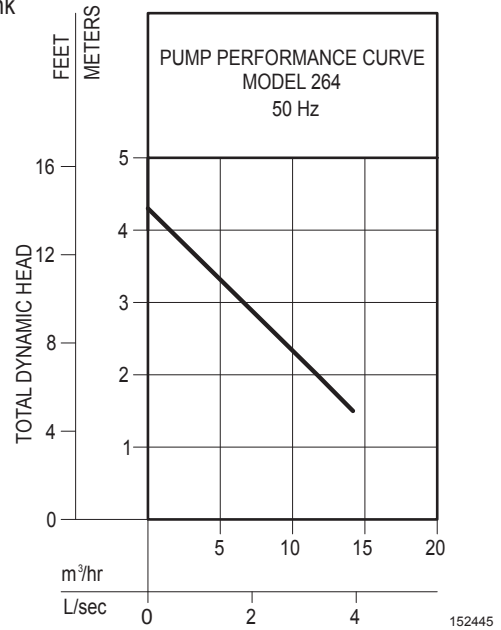
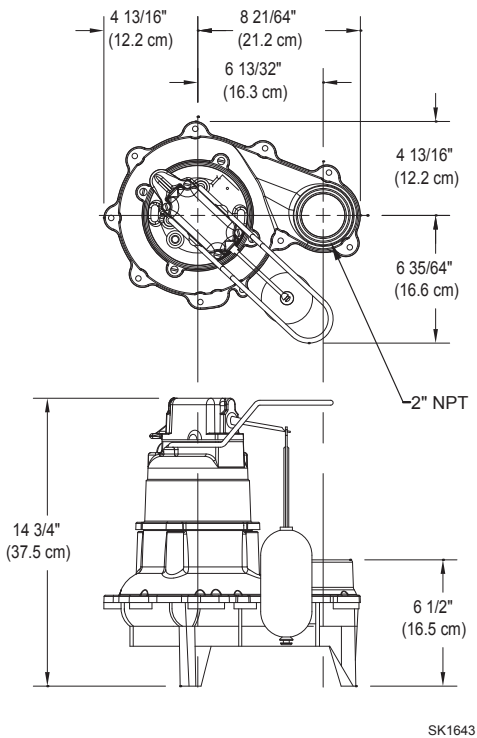

PUMP	Material	
	Pump Housing	Cast iron
Impeller	Engineered plastic w/ metal insert	
Shaft Seal	Carbon and ceramic	
Seal and gasket	Neoprene	
Power Cord	16-3 SJEOW	
PUMP	Design Features	
	Impeller	Non-clogging vortex
Bearings	Sleeve bearing upper/lower	
Solid Passing	50 mm (2") spherical solids	
Power Cord Length	5 m (15') standard	
MOTOR	Motor Housing	Cast iron
	Type	Permanent split capacitor
	RPM	1400
	Insulation Class	B
	Motor Protection	Auto reset thermal overload
	Protection Class	IPX8
	Cooling	Oil filled
	Maximum Fluid Temperature	54°C (130°F)
Discharge Size	2" NPT	
Max. Submersion Depth	6 m (20')	
Hardware	Stainless steel	
On/Off Point	31.8 cm (12½") / 11.4 cm (4½")	



Model	Mode	Volt	Ph	Amp	Motor		Weight	
					KW (p1)	HP	Kg.	Lbs.
U264	Auto	220	1	4.9	0.94	4/10	16	36
V264	Non	220	1	4.9	0.94	4/10	16	36

266, 267, 268



FEATURES:

- Cast iron motor housing with powder coated epoxy finish
- Designed to provide great heat dissipation from the motor
- Recessed, non-clogging vortex impeller design provides great solids-passing capability

APPLICATIONS:

- Wastewater/sewage handling
- Dewatering
- Water transfer

OPTIONAL:

- Extra duty option for ambient water temperature of 60°C (140°F).
- Cast iron impeller available on models 266 and 267, standard on model 268.
- Additional cord lengths available in 8 m (25'), 11 m (35') and 15 m (50').
- Available with a type E/F (5 or 10 m), G (2 or 10 m) or I (5 m) plug.

* Power cords less than 10 m (33') are intended for indoor use only.

Automatic Design

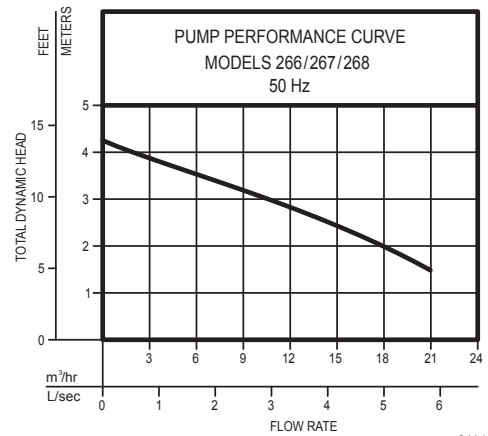
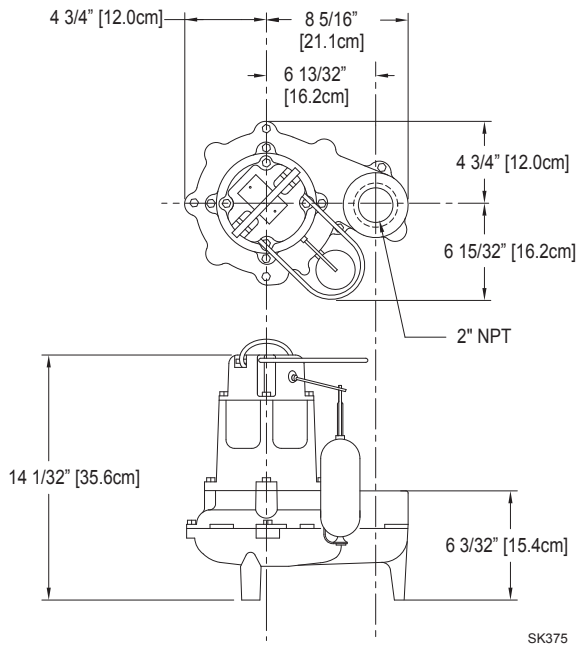

011498

		Material		
PUMP	Pump Housing	Cast iron		
	Base	266: engineered plastic 267, 268: cast iron		
	Impeller	Engineered plastic w/ metal insert		
	Shaft Seal	Carbon and ceramic		
	Seal and gasket	Neoprene		
	Power Cord	SOW/SOOW (CE model H07RN-F)		
	Design Features			
	Impeller	Non-clogging vortex		
	Bearings	Sleeve bearing upper/lower		
	Solid Passing	50 mm (2") spherical solids		
	Power Cord Length	3 m (9') auto, 5 m (15') nonauto		
MOTOR	Motor Housing	Cast iron		
	Type	Split phase		
	RPM	1400		
	Rotor	AISI 1215 cold roll steel		
	Insulation Class	B		
	Motor Protection	Auto reset thermal overload		
	Protection Class	IPX8		
	Cooling	Oil filled		
	Maximum Fluid Temperature		54°C (130°F)	
	Discharge Size		2" NPT	
Max. Submersion Depth		6 m (20')		
Hardware		Stainless steel		
On/Off Point		30.4 cm (12") / 10.1 cm (4")		



Model	Single Seal	Mode	Volt	Ph	Amp	Motor		Weight	
						KW (p1)	HP	Kg.	Lbs.
U266		Auto	220	1	4.4	0.7	1/2	19	42
V266		Non	220	1	4.4	0.7	1/2	19	42
U267		Auto	220	1	4.4	0.7	1/2	22	49
V267		Non	220	1	4.4	0.7	1/2	22	49
U268		Auto	220	1	4.4	0.7	1/2	23	51
V268		Non	220	1	4.4	0.7	1/2	23	51

270/4270, 271/4271



FEATURES:

- Cast iron motor housing with powder coated epoxy finish
- Designed to provide great heat dissipation from the motor
- Recessed, non-clogging vortex impeller design provides great solids-passing capability
- Double seal models prevent leaks and damage to seals or bearings during dry-run conditions.

APPLICATIONS:

- Wastewater/sewage handling
- Dewatering
- Water transfer

OPTIONAL:

- Additional cord lengths available in 8 m (25'), 11 m (35') and 15 m (50').
- Available with a type E/F (5 or 10 m), G (5 or 10 m) or I (5 m) plug.

* Power cords less than 10 m (33') are intended for indoor use only.

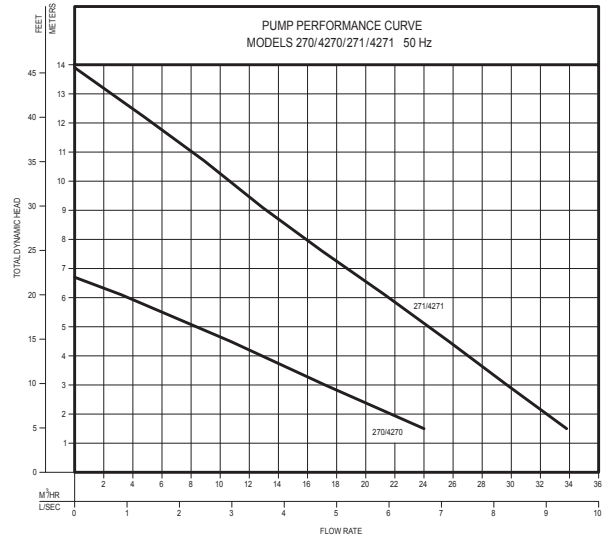

Single Seal Design

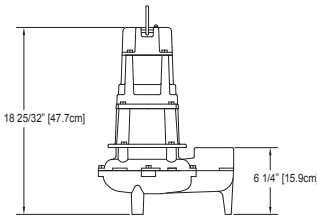

Double Seal Design

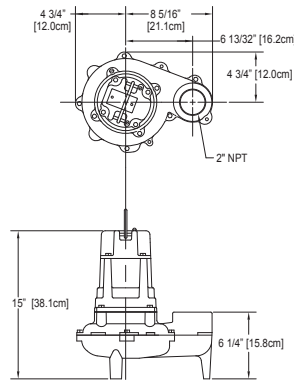

SK1532



Model		Mode	Volt	Ph	Amp	Motor		Weight	
Single Seal	Double Seal					KW (p1)	HP	Kg.	Lbs.
WU270		Auto	220	1	6.2	1.1	1	22	49
V270		Non	220	1	6.2	1.1	1	22	49
	V4270	Non	220	1	6.2	1.1	1	33	73
WU271		Auto	220	1	8.5	1.7	1	22	49
V271		Non	220	1	8.5	1.7	1	22	49
	V4271	Non	220	1	8.5	1.7	1	33	73

PUMP	Material	
	Pump Housing	Cast iron
	Base	270/271: engineered plastic 4270/4271: cast iron
	Impeller	Engineered thermoplastic or bronze
	Shaft Seal	Carbon and ceramic
	Seal and gasket	Neoprene
	Bearings	High carbon chrome steel
	Power Cord	SOW/SOOW (CE model H07RN-F)
	Design Features	
	Impeller	Non-clogging vortex
Bearings	Sleeve bearing upper/ball bearing lower	
Solid Passing	50 mm (2") spherical solids	
Power Cord Length	6 m (20') standard	
MOTOR	Motor Housing	Cast iron
	Type	Permanent split capacitor
	RPM	2800
	Rotor	AISI / 144 steel or SIS S45C steel
	Insulation Class	B
	Motor Protection	Auto reset thermal overload
	Protection Class	IXP8
	Cooling	Oil filled
Maximum Fluid Temperature		54°C (130°F)
Discharge Size		2" NPT
Max. Submersion Depth		6 m (20')
Hardware		Stainless steel



FEATURES:

- Cast iron motor housing with powder coated epoxy finish
- Automatic units include a float-operated, submersible 2-pole mechanical switch.
- Small footprint design allows for easy installation
- Finned motor housing design provides great heat dissipation

APPLICATIONS:

- Wastewater/sewage handling
- Dewatering
- Water transfer

OPTIONAL:

- Available with a 3" flange.
- Additional cord lengths available in 8 m (25'), 11 m (35') and 15 m (50').
- Single phase models available with a type E/F (5 or 10 m), G (10 m) or I (5 m) plug.
- CE rated AK models available with a 10 m (33') cord and no molded plug.

* Power cords less than 10 m (33') are intended for indoor use only.

Single Seal Design

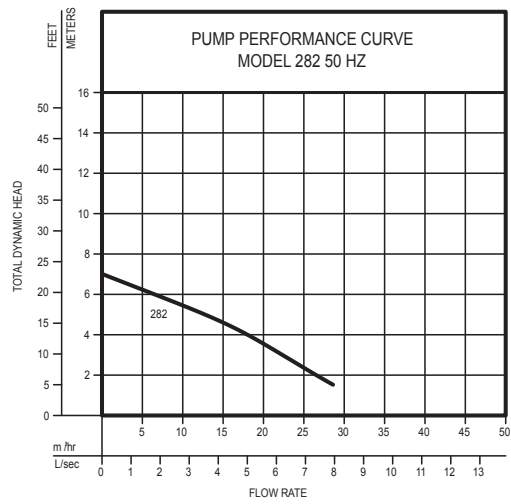
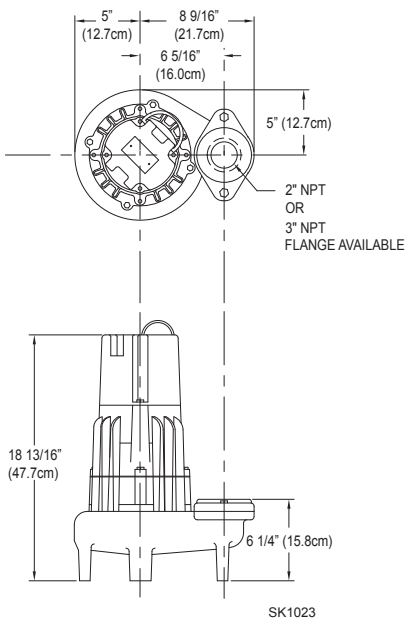

012446



Model	Mode	Volt	Ph	Amp	Motor		Weight	
					KW (p1)	HP	Kg.	Lbs.
U282	Auto	220	1	5.7	1.0	1/2	37	82
V282	Non	220	1	5.7	1.0	1/2	37	82
AK282	Non	380	3	1.6	0.8	1/2	37	82

Material		
PUMP	Pump Housing	Cast iron
	Impeller	Cast iron
	Shaft Seal	Carbon and ceramic
	Seal and gasket	Neoprene
	Bearings	High carbon chrome steel
	Power Cord	SOW/SOOW (CE model H07RN-F)
Design Features		
Impeller	Non-clogging vortex	
Bearings	Ball bearing upper/lower	
Solid Passing	50 mm (2") spherical solids	
Power Cord Length	3 m (10') auto, 5 m (15') nonauto	
MOTOR	Motor Housing	Cast iron
	Type	Permanent split capacitor or 3 Ph
	RPM	1400
	Rotor	SAE 1117 carbon steel
	Insulation Class	B
	Motor Protection	Auto reset thermal overload (1 Ph)
	Protection Class	IXP8
	Cooling	Oil filled
Maximum Fluid Temperature		54°C (130°F)
Discharge Size		2" NPT
Max. Submersion Depth		6 m (20')
Hardware		Stainless steel
On/Off Point		41.9 cm (16½") / 13.3 cm (5¼")

292, 293, 294



FEATURES:

- Cast iron motor housing with powder coated epoxy finish
- Automatic units equipped with float-operated, submersible mechanical switch
- Small footprint design allows for easy installation
- Finned and oil-filled motor housing design provides great heat dissipation

APPLICATIONS:

- Wastewater/sewage handling
- Dewatering
- Water transfer

OPTIONAL:

- Available with a 3" NPT flange.
- Additional cord lengths available in 8 m (25'), 11 m (35'), 15 m (50').
- Single phase models available with a type E/F (5 or 10 m), G (2 or 10 m) or I (5 m) plug.

* Power cords less than 10 m (33') are intended for indoor use only.

Automatic Design

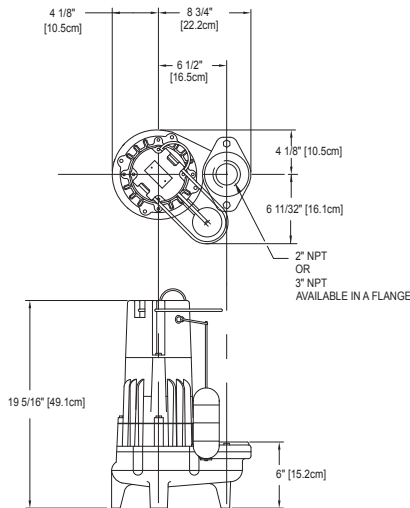

SK863

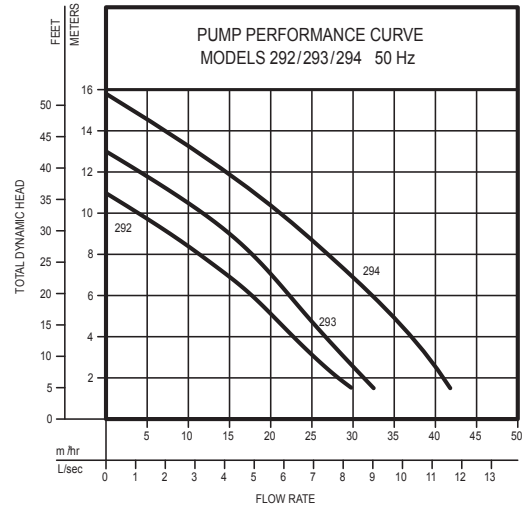

012446

		Material		
PUMP	Pump Housing	Cast iron		
	Impeller	Bronze		
	Shaft Seal	Carbon and ceramic		
	Seal and gasket	Neoprene		
	Bearings	High carbon chrome steel		
	Power Cord	SOW/SOOW (CE model H07RN-F)		
			Design Features	
	Impeller	Non-clogging vortex		
	Bearings	Ball bearing upper/lower		
	Solid Passing	50 mm (2") spherical solids		
Power Cord Length	6 m (20') standard			
MOTOR	Motor Housing	Cast iron		
	Type	Permanent split capacitor or 3 Ph		
	RPM	2800		
	Rotor	SAE 1117 carbon steel		
	Insulation Class	B		
	Motor Protection	Auto reset thermal overload (1 Ph)		
	Protection Class	IPX8		
	Cooling	Oil filled		
Maximum Fluid Temperature		54°C (130°F)		
Discharge Size		2" NPT		
Max. Submersion Depth		6 m (20')		
Hardware		Stainless steel		
On/Off Point		37.5 cm (14 3/4") / 12.7 cm (5")		

Model	Single Seal	Mode	Volt	Ph	Amp	Motor		Weight	
						KW (p1)	HP	Kg.	Lbs.
U292		Auto	220	1	7.4	1.5	1/2	40	88
V292		Non	220	1	7.4	1.5	1/2	40	88
AK292		Non	380	3	3.0	1.7	1/2	40	88
U293		Auto	220	1	8.2	1.8	1	42	93
V293		Non	220	1	8.2	1.8	1	40	88
AK293		Non	380	3	3.5	1.8	1	40	88
U294		Auto	220	1	14.3	2.8	1-1/2	41	90
V294		Non	220	1	14.3	2.8	1-1/2	41	90
AK294		Non	380	3	4.7	2.7	1-1/2	41	90

840, 841



FEATURES:

- Cast iron motor housing with powder coated epoxy finish
- Finned motor housing design provides great heat dissipation
- Cutter automatically alternates direction to enhance blade life and free hang-ups (model 840 only).
- Moisture probes and leads

APPLICATIONS:

- Low pressure sewer systems
- High head sewage systems
- Municipal, commercial and industrial

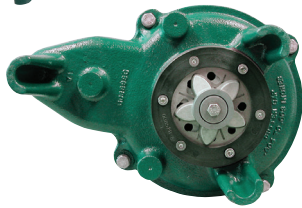

OPTIONAL:

- Additional cord lengths available in 8 m (25'), 11 m (35') and 15 m (50').
- Available with a CE rated 10 m (33') H07RN cord, sensor cord and no molded plug.

* Power cords less than 10 m (33') are intended for indoor use only.

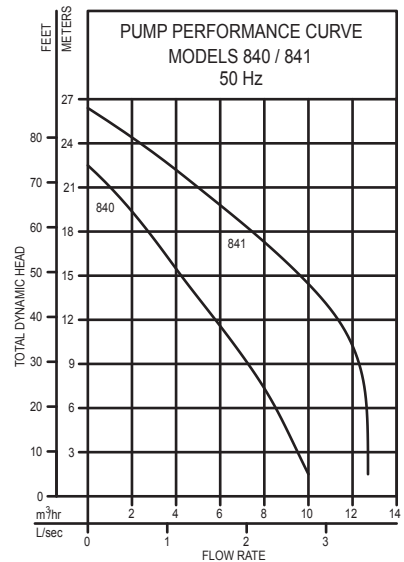

A00648

Model 840

Model 841

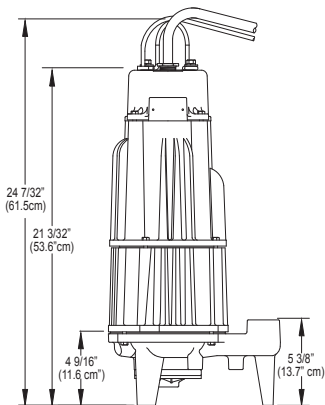

SK1322

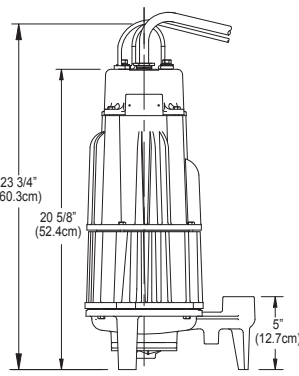

SK2365



Model	Single Seal	Mode	Volt	Ph	Amp	Motor		Weight	
						KW (p1)	HP	Kg.	Lbs.
V840	Non	220	1	12.0	2.8	2	60	132	
AK840	Non	380	3	4.4	2.5	2	60	132	
V841	Non	220	1	12.0	2.8	2	60	132	
AK841	Non	380	3	4.4	2.5	2	60	132	

PUMP	Material	
	Pump Housing	Cast iron
	Impeller	Bronze
	Shaft Seal	Carbon and ceramic
	Seal	Neoprene
	Bearings	High carbon chrome steel
Power Cord	SOW/SOOW (CE model H07RN-F)	
MOTOR	Design Features	
	Impeller	Non-clogging vortex
	Bearings	Ball bearing upper/lower
	Power Cord Length	6 m (20') standard
	Motor Housing	Cast iron
	Type	Capacitor start capacitor run or 3 Ph
	RPM	2800
	Rotor	ANSI 416 stainless steel
	Insulation Class	F
	Motor Protection	Auto reset thermal overload (1 Ph) or Thermal sensor (3 Ph)
Protection Class	IPX8	
Cooling	Oil filled	
Maximum Fluid Temperature	54°C (130°F)	
Discharge Size	1 1/4" NPT	
Max. Submersion Depth	9 m (30')	
Hardware	Stainless steel	
Cutter/Cutter Plate	Stainless steel / Rockwell C 55-60	

912 Series Preassembled Package System

FEATURES:

- 100% preassembled
- Durable polyethylene or poly-structure foam construction basin
- Cast iron pump with non-clogging vortex impeller design
- Pump passes 50 mm (2") spherical solids
- Pre-manufactured inlet for easy installation (flex-coupling provided by others)
- Gasket-sealed covers reduce odors

APPLICATIONS:

- New construction or additions
- Sewage removal from locations lower than gravity sewer main or if sewer main is not accessible
- Villas, beach houses, basements or vacation cabins

SYSTEM INCLUDES:

- Cast iron pump
- Basin with DN100 (4") PVC or cast iron hub
- DN50 (2") PVC discharge pipe with 5 mm (3/16") vent hole drilled
- PSF cover with threaded 2" vent and 2" discharge design
- Available with alarms and preinstalled alarm float



Poly-molded basin (top discharge)

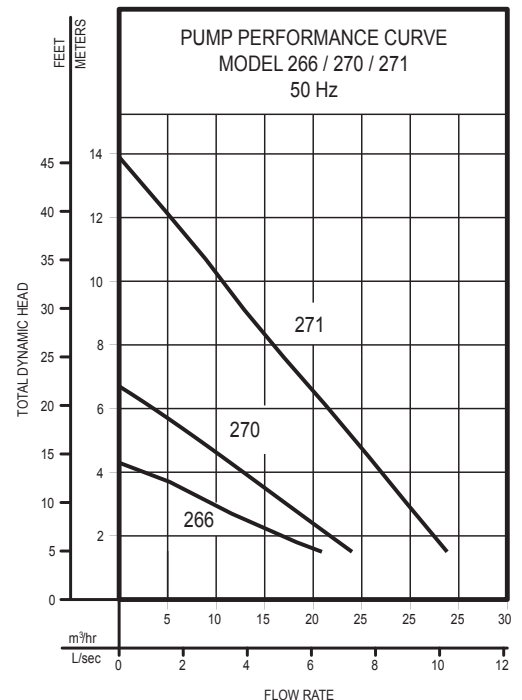
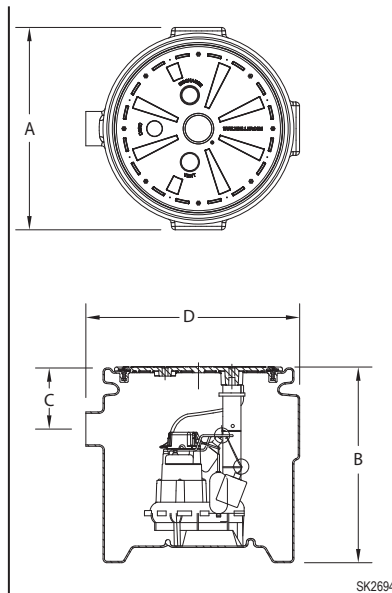
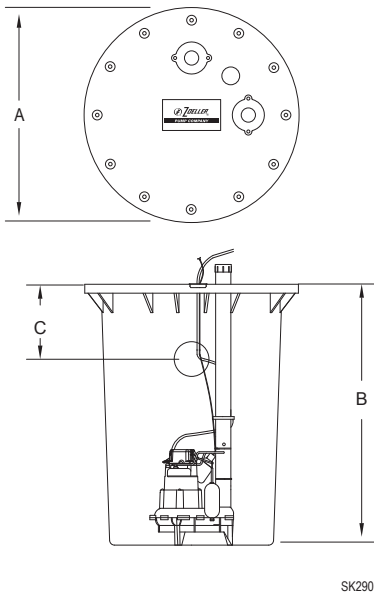

Size	Dimension cm (in)				Capacity	Material
	A	B	C	D		
46 x 76 cm (18" x 30")	55.2 cm (21¾")	76.5 cm (30⅛")	26.7 cm (10½")	N/A	113 liters (30 gal)	Poly-structure foam
61 x 91 cm (24" x 36")	76.2 cm (30")	93 cm (36⅝")	26.7 cm (10½")	N/A	246 liters (65 gal)	Poly-structure foam
61 x 61 cm (24" X 24")	67.3 cm (26½")	65.1 cm (25⅝")	20.3 cm (8")	71.1 cm (28")	155 liters (41 gal)	Polyethylene

Drain Pump Series 105, 135

Removes water from areas where gravity flow is not available

FEATURES:

- 100% factory tested and pre-assembled
- Quick & easy installation
- Oil-filled, hermetically-sealed motor with automatic reset thermal overload protection
- Compact design
- May be installed with internal trap for space savings
- Handles fluid temperatures up to 54°C (130°F)
- Durable cast iron pump with non-clogging vortex impeller passes lavatory lint (no strainer)
- Stainless steel hardware

APPLICATIONS:

- Laundry tray pumps (fits under a single or double tub)
- Wet bar sink
- Lavatories
- Condensation removal
- Residential dishwasher and garbage disposal water removal
- Dehumidifier units

OPTIONAL:

- Available with a type E/F (5 or 10 m), G (10 m) or I (5 m) plug.

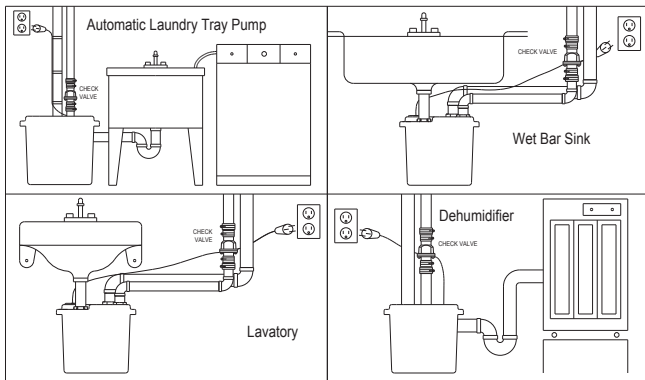

013728_2

NO INLET FILTERS OR SCREENS TO CLEAN



Model 105



Model 135 High Head

NOTE: Products may not be exactly as pictured.



EASY INSTALLATION - NO NEED TO DIG A SUMP

INCLUDES:

- Automatic cast iron pump with tank, cord seals and hardware
- Basin and gas-tight cover
- Internal discharge pipe to lid (trap supplied by others)
- Check valve (model 105: 30-0181; model 135: 30-0102)

Model	Mode	Volt	Ph	Amp	Motor		Weight	
					KW (p1)	HP	Kg.	Lbs.
105	Auto	220	1	5.2	0.72	3/10	16	35
135	Auto	220	1	3.6	0.56	4/10	22	49

TECHNICAL INFORMATION:

MODEL 105 FEATURES:

- 16 liter (4.2 gal.) polypropylene tank
- Model 53 pump
- Upper and lower sleeve bearings
- Passes 12 mm (½") spherical solids
- DN40 (1½") drain inlet (top or side); DN50 (2") NPT vent; DN40 (1½") NPT discharge
- DN40 (1½") or DN32 (1¼") slip x slip union "full flow" PVC check valve (30-0181)
- 3 m (9') cord (other cord lengths available upon request)
- Shipping wt. 16 kg. (35 lbs.)
- Max head: 4.7 m (15.5')
- Max. flow: 10.1 m³/hr (44 GPM)

MODEL 135 FEATURES:

- 23 liter (6 gal.) polyethylene tank
- Model 152 pump
- Upper sleeve bearing and lower ball bearing running in a bath of oil
- Passes 19 mm (¾") spherical solids
- DN50 (2") NPT drain inlet (side); DN50 (2") NPT vent; DN 40 (1½") NPT discharge
- DN40 (1½") solvent weld, "full flow" PVC check valve (30-0102)
- 6 m (20') cord (other cord lengths available upon request)
- Shipping wt. 22 kg. (48 lbs.)
- Max head: 9.8 m (32')
- Max. flow: 13.4 m³/hr (59.2 GPM)

BASIN FEATURES:

- Corrosion-resistant
- High capacity
- Gas-tight lid
- DN50 (2") NPT vent
- DN40 (1½") NPT discharge
- DN50 (2") NPT inlet - (model 135);
- DN40 (1½") drain inlet side or top (model 105)
- Threaded connections for easy installation
- Temperature rated 54°C (130°F)

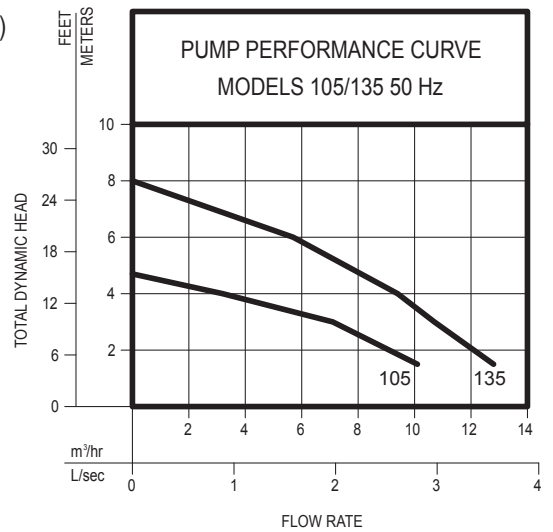

151845

BASIN DIMENSIONS

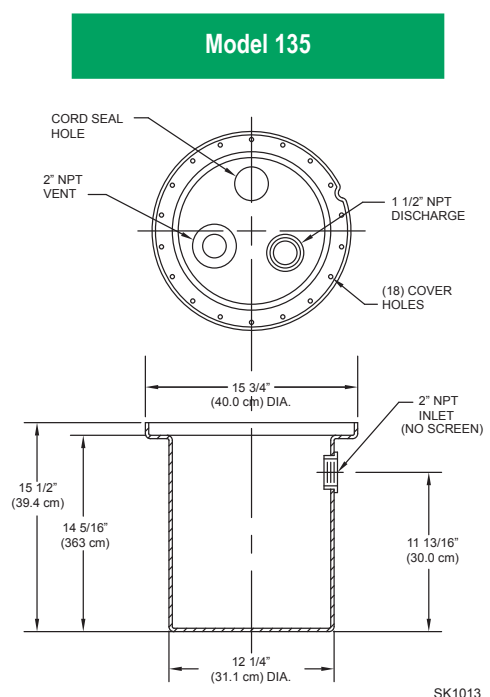
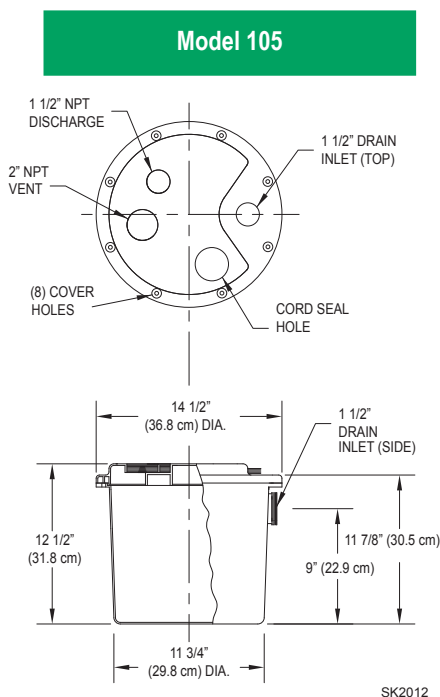

371, 372, 373



FEATURES:

- Continuous-duty evaporative cooling pumps
- Cast iron motor housing with powder coated epoxy finish
- Designed to provide great heat dissipation from the motor
- Recessed, non-clogging vortex impeller design provides great solids-passing capability

APPLICATIONS:

- Poultry industry
- Wastewater handling
- Dewatering
- Water transfer

OPTIONAL:

- Additional cord lengths available in 8 m (25'), 11 m (35') and 15 m (50').
- Available with a type E/F (5 or 10 m), G (2 or 10 m) or I (5 m) plug.

* Power cords less than 10 m (33') are intended for indoor use only.

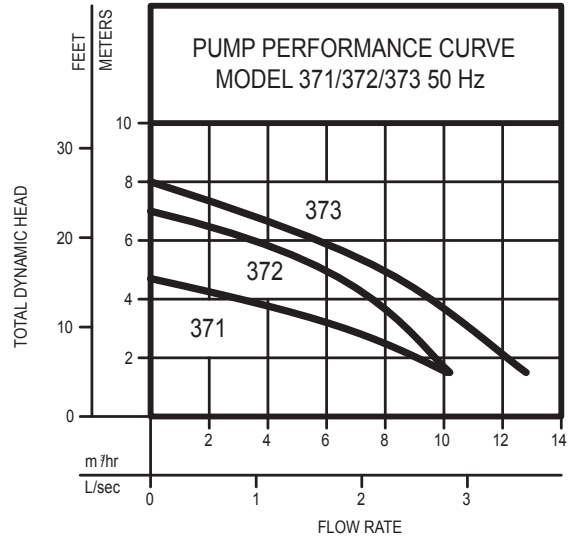

152576

Model 371

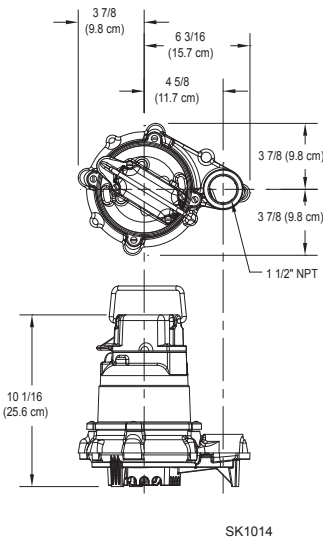

Model 372

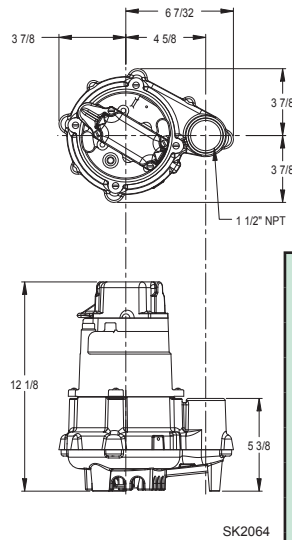

Model	Single Seal	Mode	Volt	Ph	Amp	Motor		Weight	
						KW (p1)	HP	Kg.	Lbs.
V371	Non	220	1	5.2	0.72	1/3	10	21	
V372	Non	220	1	2.6	0.46	1/3	15	32	
V373	Non	220	1	3.6	0.56	1/2	17	37	

Material	
Pump Housing	Cast iron
Impeller	Engineered thermoplastic
Shaft Seal	Silicon carbide / carbon
Seal and gasket	Neoprene
Bearings	High carbon chrome steel
Power Cord	H07RN-F
Design Features	
Impeller	Non-clogging vortex
Bearings	Sleeve bearing upper/sleeve ball bearing lower
Solid Passing	12 mm (½") or 19 mm (¾") spherical solids
Power Cord Length	8 m (25') standard
MOTOR	
Motor Housing	Cast iron
Type	Shaded pole, permanent split capacitor
RPM	1300 or 2800
Rotor	SAE 1117 carbon steel
Insulation Class	B
Motor Protection	Auto reset thermal overload
Protection Class	IXP8
Cooling	Oil filled
Maximum Fluid Temperature	54°C (130°F)
Discharge Size	1½" NPT
Max. Submersion Depth	6 m (20')
Hardware	Stainless steel

4290, 4291



FEATURES:

- Cast iron motor housing with powder coated epoxy finish
- Finned motor housing design provides great heat dissipation
- Recessed, non-clogging vortex impeller design provides great solids-passing capability
- Double seal models prevent leaks and damage to seals or bearings during dry run conditions.

APPLICATIONS:

- Agricultural
- Lagoon recirculation systems
- Sump pit systems

OPTIONAL:

- Available with a 3" NPT flange.
- Additional cord lengths available in 23 m (75') and 30 m (100').
- Single phase models available with a type E/F (10 m) or G plug.
- Model V4290 is available with a type I (15 m) plug.
- CE rated AK models available with a 10 m (33') cord and no molded plug.

* Power cords less than 33' (10 m) are intended for indoor use only.

Nonautomatic Design

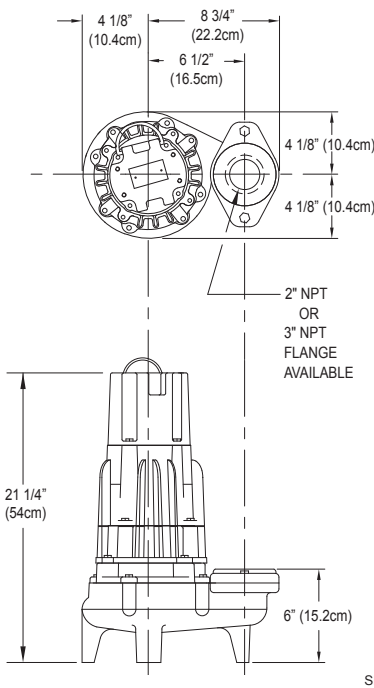

SK1619

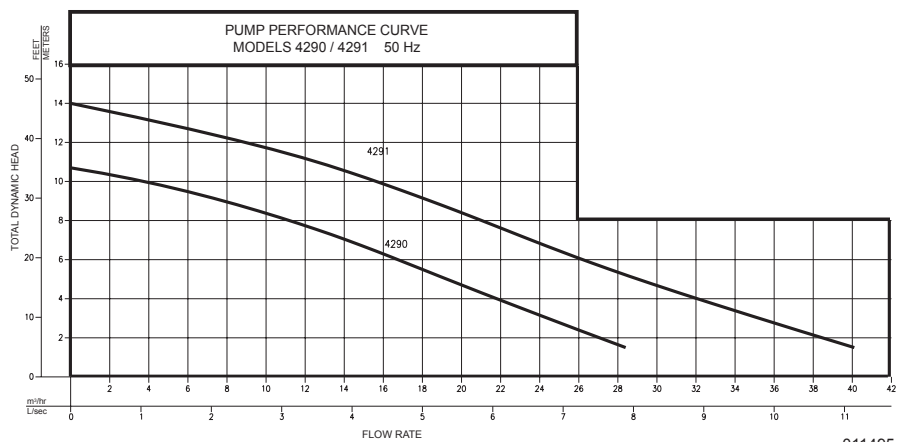

011495

		Material	
PUMP	Pump Housing	Cast iron	
	Impeller	Bronze	
	Shaft Seal	Silicon carbide / carbon (upper) Silicon carbide / silicon carbide (lower)	
	Seal and gasket	Neoprene	
	Bearings	High carbon chrome steel	
	Power Cord	SOW/SOOW (CE model H07RN-F)	
		Design Features	
MOTOR	Impeller	Non-clogging vortex	
	Bearings	Ball bearing upper/lower	
	Solid Passing	38 mm (1½") spherical solids	
	Power Cord Length	15 m (50') standard	
	Motor Housing	Cast iron	
	Type	Permanent split capacitor or 3 Ph	
	RPM	2800	
	Rotor	ANSI 416 stainless steel	
	Insulation Class	B	
	Motor Protection	Auto reset thermal overload (1 Ph)	
Protection Class	IPX8		
Cooling	Oil filled		
Maximum Fluid Temperature		54°C (130°F)	
Discharge Size		2" NPT	
Max. Submersion Depth		6 m (20')	
Hardware		Stainless steel	



Model	Mode	Volt	Ph	Amp	Motor		Weight	
					KW (p1)	HP	Kg.	Lbs.
V4290	Non	220	1	5.9	1.4	1	46	101
AK4290	Non	380	3	2.3	1.4	1	46	101
V4291	Non	220	1	14.0	2.8	2	47	104
AK4291	Non	380	3	3.5	2.1	2	47	104

Qwik Jon® Ultima Model 202 Sewage Removal System



INSTALL A BATHROOM ALMOST ANYWHERE

- Compact design, pumps any direction.
- Preassembled system for easy installation.
- No need to destroy or elevate floor.
- Reduce construction cost.
- Add value to your property.
- Designed to accommodate a toilet, lavatory, bathtub and/or shower
- Grinder tank can be installed free-standing or behind the wall.
- Zoeller patent-pending cutting system for pumping fecal matter and sanitary articles which may occasionally be dropped into the toilet.*

The smart solution for your sewage removal needs when gravity flow is not available.

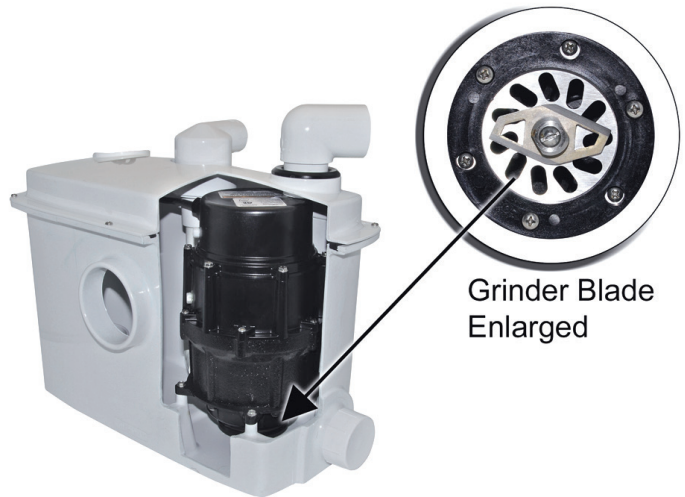

The Qwik Jon®
Ultima
by Zoeller



Our grinder pump provides over 60,000 cuts per minute.



TECHNICAL INFORMATION

FEATURES:

- Non-corrosive, engineered thermoplastic grinder pump
- Pump 100% factory tested after assembly
- All stainless steel hardware
- Works with 1" discharge (¾" discharge adaptable)
- IAMPO certified, durable ABS tank with white finish
- Built-in check valve
- 2" MPT and 1-1/2" slip side inlets

GENERAL INFORMATION:

Dimensions 37 cm (14 ½") (H) x 51 cm (20 1/8") (W) x 24 cm (9 3/16") (D)

Possible connections Toilet, vanity basin, shower, bidet

Normal operating temp Maximum temperature 54°C (130°F)

Motor power rating 0.7 KW

Motor protection class IPX8

Pumping liquid pH level 4 to 10

PUMP:

- 2800 RPM, 3.4 FLA
- Automatic reset thermal overload-protected motor
- 40-45 Rockwell C, 410 stainless steel cutter and cutter disc
- Carbon / ceramic mechanical shaft seal
- Non-clogging vortex impeller
- Upper and lower ball bearings running in a bath of oil

OPTIONAL:

- Extension kit for behind-the-wall installations (P/N 10-2123)

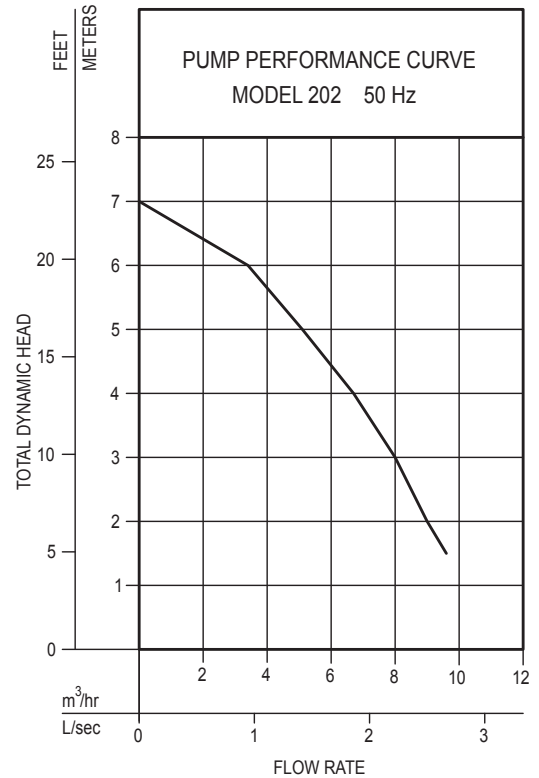

150869

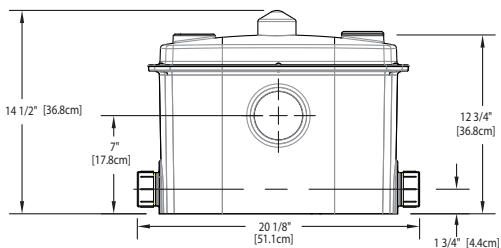
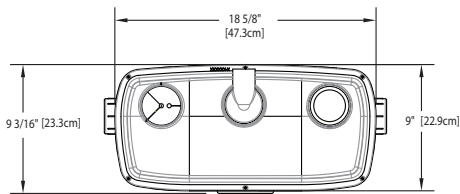

SK2674

Model	Mode	Volt	Ph	Amp	Motor		Weight	
					KW (p1)	HP	Kg.	Lbs.
202	Auto	220	1	3.4	0.7	1/2	15	34

bathrooms



basements



cottages



pool houses

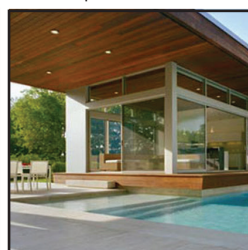

holiday homes



*Zoeller Qwik Jon Ultima is designed for handling human waste, toilet paper and water. Units can occasionally accept disposal of sanitary items such as condoms, tampons and sanitary pads. It is NOT manufacturer's recommendation to dispose of these items in the toilet which may cause sewage system to fail. **Do not discharge acids, alkaloids, solvents paint, food waste, metal, wood, building material or any corrosive liquid that could halt or damage the unit. Disregarding the above might damage the unit and shall void your warranty. Please consult factory for specific application.

Oil Guard® System Model 941



Simplex system shown with model V53 pump

Designed to help protect the environment and equipment from the dispersion of oils and/or hydrocarbons.

APPLICATIONS:

- Transformer vaults
- Manufacturing facilities
- Any application where there is a need to remove water containing oil

SYSTEMS:

- Operation of the Zoeller Oil Guard® System has been independently verified by OnSpeX, div. of CSA, when installed in accordance with our instructions.
- Choose from four pump models. Includes pump, switch and alarm (optional control panel).

PUMP FEATURES:

- Durable cast iron construction with powder coated epoxy finish and all stainless steel fittings.

OIL SMART® LIQUID ALARM PANEL

SPECIFICATION:

- 240 VAC
- Type 4X non-metallic enclosure
- External dimensions: 15 cm x 15 cm x 10 cm (6" x 6" x 4")
- 94V-2 Polycarbonate, IP-56 rating

FEATURES:

- External mounting feet for quick installation to any flat surface
- Silence switch and test switch
- Mounting hardware included
- Red beacon alarm light
- Alarm automatically resets
- High 85 decibel audible alarm and dry contact
- Easily accessible terminal blocks
- Liquid Smart alarm switch 6 m (20') cord; available up to 61 m (200')



Model 10-3149

SIMPLEX PANEL FEATURES:

- Oil Smart® liquid alarm sensor
- Oil Smart® pump switch (10-2447)
- 220 volts, single phase
- NEMA 4X watertight enclosure with lockable latch
- 30 amp motor start relay
- Pump HOA switch
- Top mounted red alarm beacon light
- 81 - 84 decibel rated alarm horn
- Horn silence and alarm test switches
- Alarm automatically resets
- Dry auxiliary alarm contacts
- Separate circuit protection for alarm
- Circuit breaker protection
- Pump run indicator light



Model 10-2284



DUPLEX ALTERNATING PANEL FEATURES:

- Oil Smart® liquid alarm sensor
- Oil Smart® pump switch (10-2447)
- Oil Smart® high-water alarm switch for high demand two-pump operation
- 220 volts, single phase
- NEMA 4X water-tight enclosure with lockable latch
- Two 30-amp motor start relays
- Pump HOA (Hand-Off-Auto) switches
- Top-mounted red alarm beacon light
- 81 - 84 decibel rated alarm horn
- Horn silence and alarm test switches
- Alarm automatically resets
- Dry auxiliary alarm contacts
- Separate circuit protection for alarm
- Pump run indicator light



Model 10-2285

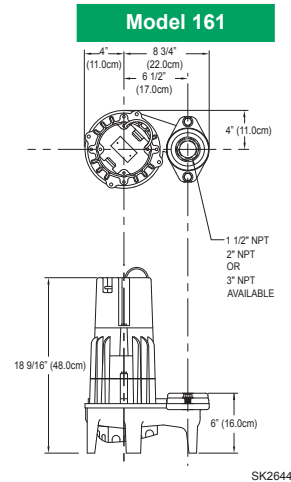
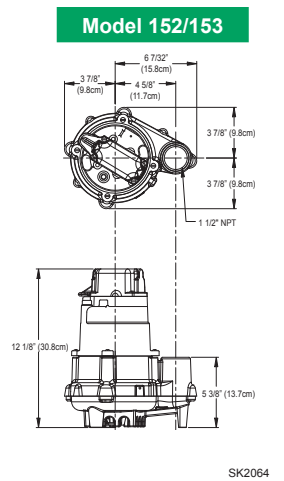
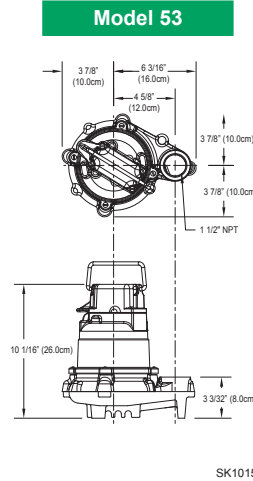
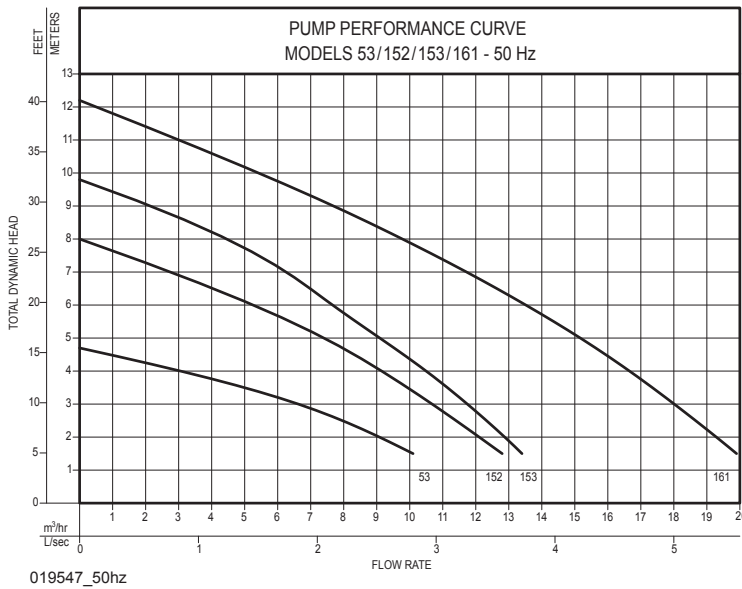

Build your own system or choose a prepackaged system, see below.

CONTROLS:

Part Number	Description	Control Panel	Oil Smart® Pump Switch	Oil Smart® Liquid Alarm Sensor	Oil Smart® High Liquid Alarm Switch
10-3149	Oil Smart® Liquid Alarm Panel	✓	---	✓	---
10-2447	Oil Smart® Pump Switch w/o Plug	---	✓	---	---
10-2284	Oil Smart® Simplex Panel	✓	✓	✓	---
10-2285	Smart® Duplex Panel	✓	✓	✓	✓

✓ (included)

CHOOSE A PREPACKAGED SYSTEM:

Part Number	Description	Control Panel	Nonauto Pump Part No.
941-0005	Oil Smart® Control, Simplex with 0.3 HP V53	10-2284	53-0073
941-0006	Oil Smart® Control, Simplex with 0.4 HP V152	10-2284	152-0016
941-0007	Oil Smart® Control, Simplex with 0.5 HP V153	10-2284	153-0013
941-0008	Oil Smart® Control, Simplex with 0.5 HP V161	10-2284	161-0070

PUMPS:

Pump	Nonauto Model	Volts	Ph	KW	HP	Amps
53-0073	V53	220	1	0.72	3/10	5.2
152-0016	V152	220	1	0.56	4/10	3.6
153-0013	V153	220	1	0.71	1/2	4.3
161-0070	V161	220	1	1.20	1/2	5.6

These systems are not designed for explosion-proof environments. Please consult factory for special options and requirements.

OPERATION:

Oil Smart® Pump Switch

When water comes in contact with the short (on) sensor, the pump will remain on until water clears the long (off) sensor. If oil comes in contact with the on sensor, the pump will not turn on; however the pump switch will activate and pump water from under the oil. Oil does not harm the system. The sensors can oscillate through oil and water.



Oil Smart® Liquid Alarm Sensor

If a high liquid comes in contact with the sensors of the Liquid Smart Alarm sensor, the sensor will send a signal to the control panel that there is a high liquid present. Simultaneously, the alarm sensor will differentiate and indicate if oil or water is present.

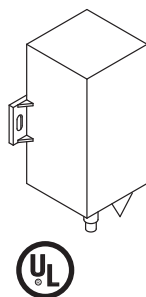

High Liquid Alarm Switch

If water continues to enter the sump and one pump cannot keep up with the inflow of water, water will make contact with the sensor of the high water two-pump demand switch. If water comes in contact with the sensor, the second pump will turn on and both pumps will continue to pump water until water clears the off sensor of the Oil Smart® switch, shutting both pumps down.

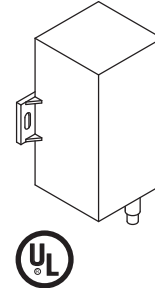

Accessories

A-PAK Alarm Systems

Zoeller recommends that ALL systems be installed with a check valve and high water alarm whether it is a small sump pump, sewage system, or a large outdoor lift station. From indoor residential systems to NEMA 4X commercial/industrial applications, Zoeller has the right alarm for the job.

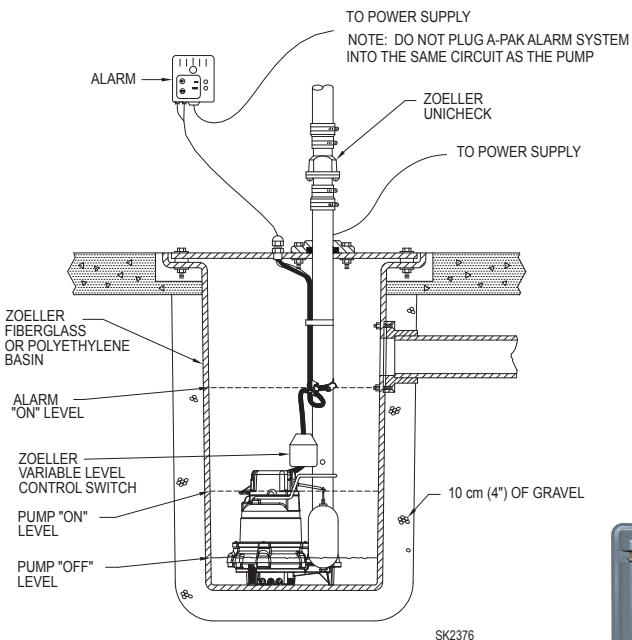

10-1675 indoor/outdoor alarm system features:

- NEMA 3R thermoplastic enclosure 16 cm x 10 cm x 8 cm (6" x 4" x 3")
- Horn is rated 88 decibels at 3 m (10')
- 5 m (15') mechanical float switch
- Silence / test switch
- UL listed to Canadian standard cULus

10-1494 A-Pak Alarm features:

- Automatic alarm reset
- Horn is rated 87 decibels at 3 m (10')
- 9V battery back-up (battery not included)
- 5 m (15') alarm (12V) tethered switch
- 2 m (6') power cord
- Auxiliary dry contacts (use P/N 10-2614)
- UL / CSA listed



Model 10-1675



Models 10-1494

Full-Flow Unichecks

The Zoeller "Full-Flow" Unicheck features flexible neoprene slip x slip unions with all stainless steel clamps and screws. This saves installation time and is simple to install. No pipe threading required. Checks back flow of water and sewer gas and features an extra wide flapper hinge to prevent hinge stress. Can be installed in a vertical or horizontal line. Available in cast iron or PVC construction.

30-0021	2" Plastic Slip x Slip Unions	Max. 4.3 psi - 10' head (30 kPa)
30-0151	2" Cast iron Slip x Slip Unions	Max. 4.3 psi - 10' head (30 kPa)
30-0023	2" Plastic Solvent welded couplings	Max. 25 psi - 58' head (172 kPa)
30-0101	2" PVC Valve/Ball Valve/Union Combination	Max. 25 psi - 58' head (172 kPa)
30-0103	2" PVC Valve/Union Combination	Max. 25 psi - 58' head (172 kPa)



30-0101



30-0103



30-0151
CAST IRON



30-0021
PVC PLASTIC

Float Switches

Zoeller has a full line offering of pump and control switches for applications pumping up or down. Constructed of PVC/Poly and available in various lengths. UL listed, mechanical switches. Float tree assemblies, hangers, weights and other accessories are available to meet your needs on any project.



CLAMP TYPE



ADJUSTABLE WEIGHT TYPE

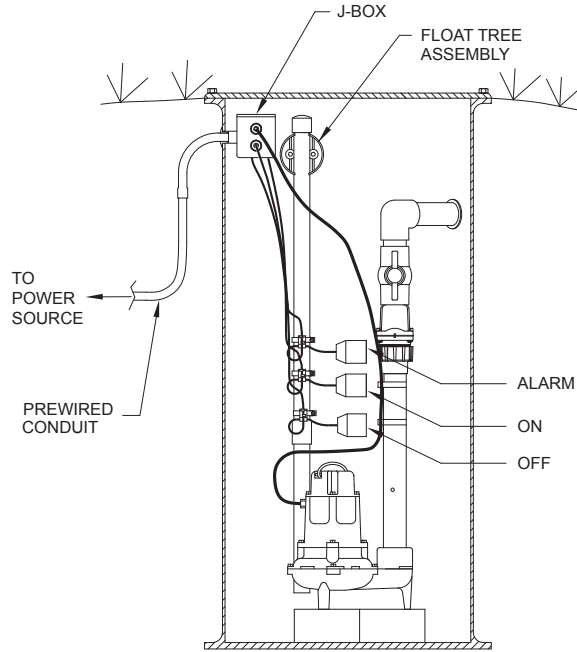

OUTDOOR BASIN

SK2233a

Disconnect and Rail Systems

Complete systems for sewage, effluent and grinder pumps can be field-installed or factory-installed in concrete, steel or fiberglass basins and tanks. Guide rails direct the pump to and from the base elbow. See FM0787.

DISCONNECT ONLY (1 1/4", 1 1/2" & 2" Discharge)

Disconnect Fitting: used for shallow systems where guide rails are not necessary (pull rod not included).



- 39-0053, 1 1/4" NPT
- 39-0001, 1 1/2" NPT
- 39-0002, 2" NPT

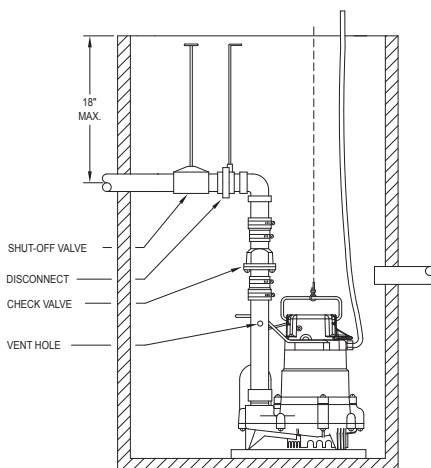

SK730

COMPLETE SYSTEMS (1 1/4", 1 1/2", 2" & 3" Discharge)

Rail & Disconnect Systems for effluent or sewage pumps allow for removal and reinstallation of pumps without getting in or removing fluid from the pit.

Guide rails direct the pump to and from the coupling base. Systems are supplied complete with coupling base, sealing plate, pump discharge elbow, and upper rail support bracket. All systems use schedule 40 pipe rails (not included).



Z-Rail Disconnect System

- 39-0134, 1-1/4" x 2" NPT
- 39-0131, 1-1/2" x 2" NPT
- 39-0128, 2" x 2" NPT
- 39-0175, 3" x 3" NPT

Pipe rails, pull rods and intermediate brackets not included.

Control Panels

An electrical panel is used on a simplex (single) pump application where automatic electrical cycling of the pump is desired for added protection in residential or commercial applications. An electrical alternator is used on a duplex (dual) pump application where automatic alternation of pumps is desired for added protection in residential or commercial applications. With one pump operating to handle normal flow, a second pump becomes operational in the event the water level continues to rise. The built-in alarm system, a standard feature, can be connected to sound when the second pump becomes operational (3-float switch system) or independently (4-float switch system). All electrical systems must be installed by a qualified electrician and according to the governing codes. Refer to the Control Panel Selection Guide on the following page for selecting the panel most appropriate for your application.

Standard Features for Simplex and Duplex Control Panels:



- HOA (hand-off-auto) toggle switch for each pump
- Green pump run pilot light for each pump
- Alarm test and silence switches
- Audible alarm with 83 to 85 decibel rating for a high-water condition
- Red alarm beacon included with NEMA 4X enclosure
- Auxiliary dry contact
- High water alarm
- Single phase: circuit breaker for each pump
- Three phase: motor protective switch with overload protection
- Magnetic starter for each pump
- Alternating mechanism (duplex only)
- Numbered terminal strip for connecting pumps and variable level float switches
- NEMA 4X: watertight enclosures
- Integral auxiliary terminal board connections (dry contact) for remote alarm devices
- 3 or 4 variable level float switch control operation
- 2 year warranty
- The use of off-the-shelf components provides for relatively easy field maintenance and repair.



Control Panel Selection Guide

Pump Data						Simplex			Duplex		
Model Number	Kw	Volts	Ph	FLA	Panel Amp Range	Part Number	Wt. kg / lbs.	Dimensions (H x W x D) centimeters / inches	Duplex	Wt. kg / lbs.	Dimensions (H x W x D) centimeters / inches
V53	0.72	220	1	5.2	0-7.0	10-3243	7/15	20x38x46 / 8"x15"x18"	10-3244	9/19	56x25x48 / 22"x10"x19"
V55	0.72	220	1	5.2	0-7.0	10-3243	7/15	20x38x46 / 8"x15"x18"	10-3244	9/19	56x25x48 / 22"x10"x19"
V98	0.77	220	1	4.7	0-7.0	10-3243	7/15	20x38x46 / 8"x15"x18"	10-3244	9/19	56x25x48 / 22"x10"x19"
V137	0.7	220	1	4.2	0-7.0	10-3243	7/15	20x38x46 / 8"x15"x18"	10-3244	9/19	56x25x48 / 22"x10"x19"
V139	0.7	220	1	4.2	0-7.0	10-3243	7/15	20x38x46 / 8"x15"x18"	10-3244	9/19	56x25x48 / 22"x10"x19"
V140	1.0	220	1	6.2	0-7.0	10-3243	7/15	20x38x46 / 8"x15"x18"	10-3244	9/19	56x25x48 / 22"x10"x19"
V145	0.9	220	1	4.5	0-7.0	10-3243	7/15	20x38x46 / 8"x15"x18"	10-3244	9/19	56x25x48 / 22"x10"x19"
V152	0.56	220	1	3.6	0-7.0	10-3243	7/15	20x38x46 / 8"x15"x18"	10-3244	9/19	56x25x48 / 22"x10"x19"
V153	0.71	220	1	4.3	0-7.0	10-3243	7/15	20x38x46 / 8"x15"x18"	10-3244	9/19	56x25x48 / 22"x10"x19"
V161	1.2	220	1	5.6	0-7.0	10-3243	7/15	20x38x46 / 8"x15"x18"	10-3244	9/19	56x25x48 / 22"x10"x19"
AK161	1.2	380	3	2.0	1.6-2.5	10-3245	8/18	25x51x56 / 10"x20"x22"	10-3052	10/22	25x53x61 / 10"x21"x24"
V162	1.7	220	1	8.0	7.0-15.0	10-2698	7/15	20x38x46 / 8"x15"x18"	10-2699	9/19	25x48x56 / 10"x19"x22"
AK162	1.8	380	3	3.0	2.5-4.0	10-3246	8/18	56x25x51 / 22"x10"x20"	10-2811	10/21	25x48x56 / 10"x19"x22"
V163	1.5	220	1	6.4	0-7.0	10-3243	7/15	20x38x46 / 8"x15"x18"	10-3244	9/19	56x25x48 / 22"x10"x19"
AK163	1.6	380	3	2.9	2.5-4.0	10-3246	8/18	56x25x51 / 22"x10"x20"	10-2811	10/21	25x48x56 / 10"x19"x22"
V165	2.0	220	1	9.6	7.0-15.0	10-2698	7/16	20x38x46 / 8"x15"x18"	10-2699	9/19	25x48x56 / 10"x19"x22"
AK165	1.8	380	3	2.0	1.6-2.5	10-3245	8/18	26x51x56 / 10"x20"x22"	10-3052	10/22	25x53x61 / 10"x21"x24"
V185	2.0	220	1	10.0	7.0-15.0	10-2698	7/16	20x38x46 / 8"x15"x18"	10-2699	9/19	25x48x56 / 10"x19"x22"
AK185	2.4	380	3	4.1	4.0-6.3	10-3251	8/18	61x25x53 / 24"x10"x21"	10-2761	10/22	25x53x61 / 10"x21"x24"
V189	2.9	220	1	14.2	7.0-15.0	10-2698	7/16	20x38x46 / 8"x15"x18"	10-2699	9/19	25x48x56 / 10"x19"x22"
AK189	2.6	380	3	4.5	4.0-6.3	10-3251	8/18	61x25x53 / 24"x10"x21"	10-2761	10/21	25x53x61 / 10"x21"x24"
V266/V267	0.7	220	1	4.4	0-7.0	10-3243	7/15	20x38x46 / 8"x15"x18"	10-3244	9/19	56x25x48 / 22"x10"x19"
V270	1.1	220	1	6.2	0-7.0	10-3243	7/15	20x38x46 / 8"x15"x18"	10-3244	9/19	56x25x48 / 22"x10"x19"
V271	1.7	220	1	8.5	7.0-15.0	10-2698	7/16	20x38x46 / 8"x15"x18"	10-2699	9/19	25x48x56 / 10"x19"x22"
V282	1.0	220	1	5.7	0-7.0	10-3243	7/15	20x38x46 / 8"x15"x18"	10-3244	9/19	56x25x48 / 22"x10"x19"
AK282	0.8	380	3	1.6	1.6-2.5	10-3245	8/18	26x51x56 / 24"x10"x21"	10-3052	10/22	25x53x61 / 10"x21"x24"
V292	1.5	220	1	7.4	7.0-15.0	10-2698	7/16	20x38x46 / 8"x15"x18"	10-2699	9/19	25x48x56 / 10"x19"x22"
AK292	1.7	380	3	3.0	2.5-4.0	10-3246	8/18	56x25x51 / 22"x10"x20"	10-2811	10/21	25x48x56 / 10"x19"x22"
V293	1.8	220	1	8.2	7.0-15.0	10-2698	7/16	20x38x46 / 8"x15"x18"	10-2699	9/19	25x48x56 / 10"x19"x22"
AK293	1.8	380	3	3.5	2.5-4.0	10-3246	8/18	56x25x51 / 22"x10"x20"	10-2811	10/21	25x48x56 / 10"x19"x22"
V294	2.8	220	1	14.3	7.0-15.0	10-2698	7/16	20x38x46 / 8"x15"x18"	10-2699	9/19	25x48x56 / 10"x19"x22"
AK294	2.7	380	3	4.7	4.0-6.3	10-3251	8/18	61x25x53 / 24"x10"x21"	10-2761	10/21	25x53x61 / 10"x21"x24"
V840	2.8	220	1	12.0	7.0-15.0	10-3157	9/19	56x25x48 / 22"x10"x19"	10-3158	12/26	81x43x61 / 32"x17"x24"
AK840	2.5	380	3	4.4	4.0-6.3	10-3159	10/21	81x43x61 / 32"x17"x24"	10-3160	12/26	61x25x53 / 24"x10"x21"
V841	2.8	220	1	12.0	7.0-15.0	10-3247	7/16	56x25x51 / 22"x10"x20"	10-3248	11/25	81x43x61 / 32"x17"x24"
AK841	2.5	380	3	4.4	4.0-6.3	10-3249	8/18	56x25x51 / 22"x10"x20"	10-3250	10/22	61x25x53 / 24"x10"x21"

Plug Types

None	E / F - CEE 7/7 Plug	G - British Standard 1363	I - CPCS - CCCC (China)
No molded plug.			

NOTES



COMPANY

Zoeller Family of Water Solutions™

ABOUT THE ZOELLER FAMILY OF WATER SOLUTIONS

Founded in 1939, Zoeller Company is the oldest independently-owned professional pump manufacturer in North America. Headquartered in Louisville, Kentucky USA, Zoeller has over 600 employees worldwide and a total of 550,000 sq. ft. of manufacturing facilities from our six operations in North America and Asia.

For over seventy years, Zoeller Company has established itself as an innovative leader in pumping equipment and water treatment systems by continuous research and development. The quality of our products is demonstrated by UL, CSA, CE, and NSF listings as well as continued growth throughout the United States, Canada, Mexico, and over 40 other countries around the globe. The company has also expanded to include four brands, which have become the foundation of Zoeller.



The original Zoeller product line now resides in Zoeller Pump Company, which offers a broad range of submersible pumps from fractional to 7½ HP for residential and commercial sump, effluent, dewatering and grinding applications.



Flint & Walling, founded in 1886 in Kendallville, Indiana USA, is the only pump company in the U. S. to manufacture its own motor for jet and centrifugal pumps. This product line specializes in deep well pumps that range from 5 GPM to 1,000 GPM, as well as centrifugal, jet, booster, and submersible pumps up to 7½ HP.



Zoeller Engineered Products provides products for storm water removal, sewage treatment, grinding, and hazardous environment applications from commercial to municipal markets. Available from ½ BHP to 100 BHP, each pump is customized by design, manufacture and installation according to exact application needs.



Clarus Environmental offers sustainable environmental products, solutions, and services for the collection, treatment, and dispersal of residential and community wastewater. This line specializes in onsite pumps, pressure sewers, biological and mechanical treatment processes, disinfection, and discharge of safe water.

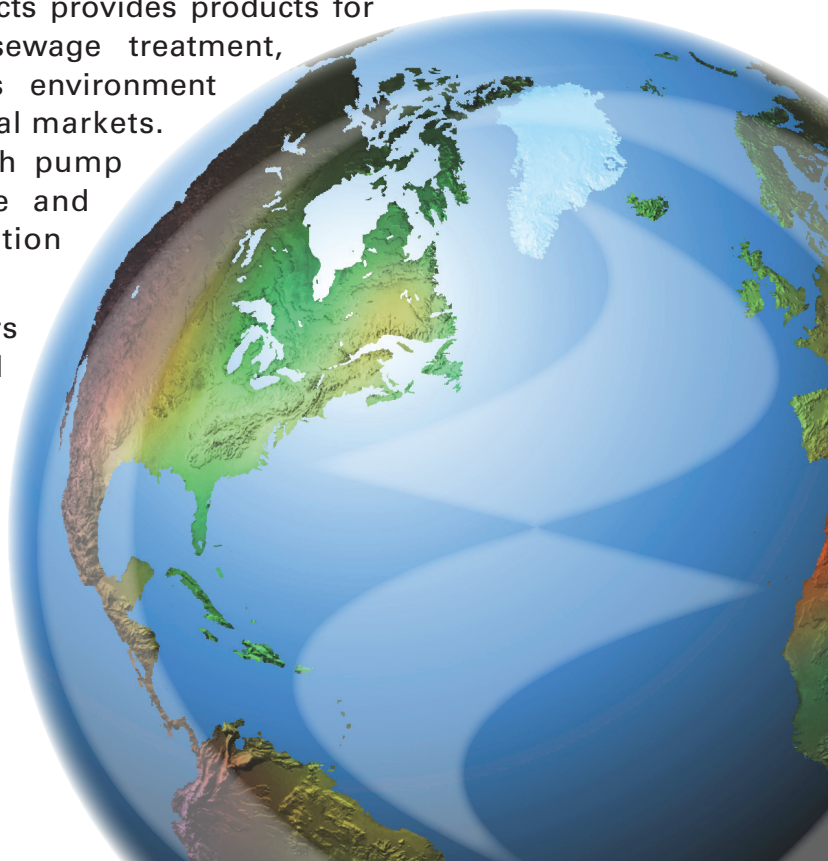

FM1540
1013
Supersedes
1211



COMPANY

Zoeller Family of Water Solutions™

3649 Cane Run Road • Louisville, KY USA 40211 • +1 (502)778-2731 • fax +1 (502)774-3624 • www.zoeller.com